

Date:

CEN

Secretariat:

Physical properties – Determination of flowability – "Rheological properties": Laboratory reference method by 'laboratory rotational viscometer'

Physikalische Eigenschaften – Bestimmung der Fließfähigkeit – Laborreferenzmethode mit [...]

Propriétés [...] – Détermination de [...] – : [...]

ICS:

Descriptors:

Contents

| | |
|--|----|
| Foreword | 3 |
| Introduction | 4 |
| 1 Scope | 5 |
| 2 Standards and other normative references | 5 |
| 3 Terms and definitions..... | 5 |
| 4 Principle | 6 |
| 5 Equipment | 6 |
| 5.1 Coaxial cylinders viscometer | 6 |
| 5.2 Thermostatic bath | 6 |
| 5.3 Sieve..... | 7 |
| 6 Test sample(s) | 7 |
| 7 Working instructions | 7 |
| 8 Calculations and expression of results | 7 |
| 9 Test report..... | 7 |
| Annex A (informative) Laboratory coaxial cylinders viscometer..... | 9 |
| Bibliography | 10 |

Foreword

This document has been prepared by HORIZONTAL-Committee // CEN/TC /..., "[...]."

This document is currently submitted to the HORIZONTAL Enquiry.

Other parts of this European Standard /HORIZONTAL Standards – Physical Properties are:

[...] - Determination of bulk density;

[...] - Determination of dry matter;

[...] - Determination of total volatile solid;

[...] - Determination of solidity;

[...] - Determination of thixotropic behaviour;

[...] - Determination of piling behaviour;

Introduction

This document is developed in the project 'Horizontal'. It is the result of desk study "**Physical properties – Flowability**" in the project and aims at a laboratory reference method for determining the flowability of sludge, soil, treated bio-waste and related wastes by means of the laboratory rotational viscometer. After discussion with all parties concerned in CEN and selection of a number of test methods described in this study will be developed further as an modular horizontal method and validated in the project 'Horizontal'.

Until now test methods determining properties of materials were often prepared in Technical Committees (TC's) working on specific products or specific sectors. In those test methods often steps as sampling, extraction, release or other processing, analyses, etc were included. In this approach it was necessary to develop, edit and validate similar procedural steps over and over again for each other product. Consequently this resulted in a lot of duplicate work. To avoid such duplication of work for parts of a testing procedure often was referred to parts of test methods from other TC's. However following problems are often encountered while using references in this way:

- 1) The referenced parts are often not edited in a way that they could easily be referred to,
- 2) the referenced parts are often not validated for the other type of material and
- 3) the updates of such test standards on products might lead to inadequate references.

In the growing amount of product and sector oriented test methods it was recognised that many steps in test procedures are or could be used in test procedures for many products, materials and sectors. It was supposed that, by careful determination of these steps and selection of specific questions within these steps, elements of the test procedure could be described in a way that they can be used for all materials and products or for all materials and products with certain specifications.

Based on this hypothesis a horizontal modular approach is being investigated and developed in the project 'Horizontal'. 'Horizontal' means that the methods can be used for a wide range of materials and products with certain properties. 'Modular' means that a test standard developed in this approach concerns a specific step in a test procedure and not the whole test procedure.

The texts of the chapters [x,x, and x] are normative; chapter [x, x] are informative chapters; annexes are normative or informative, as stated in the top lines of the annexes.

1 Scope

This Part of this European standard specifies a laboratory reference method for determining the flowability of sludge, soil, treated bio-waste and related wastes by means of the laboratory rotational viscometer.

This Part of this European Standard is applicable to sludge, soil, treated bio-waste and related wastes from:

- storm water handling
- urban wastewater collecting systems
- urban wastewater treatment plants
- treating industrial wastewater similar to urban wastewater (as defined in Directive 91/271/EEC)
- water supply treatment plants
- soils [...]
- treated biowaste [...]
- wastes [...]

This method is also applicable to sludges, soils, treated biowaste and related wastes of other origin.

2 Standards and other normative references

This European Standard incorporates by dated or undated reference, provisions from other publications. These normative references are cited at the appropriate places in the text and the publications are listed hereafter. For dated references, subsequent amendments to or revisions of any of these publications apply to this European Standard only when incorporated in it by amendment or revision. For undated references the latest edition of the publication referred to applies (including amendments).

pr EN 13702-2003 — Bitumen and bituminous binders - Determination of dynamic viscosity of modified bitumen - Part 2: Coaxial cylinders method

pr EN 13302:2002 FINAL DRAFT — Bitumen and bituminous binders - Determination of viscosity of bitumen using a rotating spindle apparatus

ASTM D 2556 — Standard tests method for apparent viscosity of adhesives having shear-rate dependent flow properties

ISO 3219 — Plastics - Polymers/resins in the liquid state or as emulsions or dispersions - Determination of viscosity using a rotational viscometer with defined shear rate

3 Terms and definitions

For the purposes of this Part of this European Standard, the terms and definitions as stated in [...] and the following terms and definitions apply.

shear stress

torque applied to turn the spindle at the set speed [prEN 13302]

shear rate

Document type: European Standard
Document subtype:
Document stage: CEN Enquiry
Document language: E

difference between the motions of a fluid near the rotating spindle and near the walls of the container at a given distance between rotating spindle and wall of the container [prEN 13302]

dynamic viscosity

ratio between the applied shear stress and the velocity gradient. It is the measure of the resistance to flow of the liquid. The SI unit of dynamic viscosity is the Pascal second (Pa.s). Millipascal second (mPa.s) is a frequently used sub-unit [prEN 13302]

newtonian fluid

fluid having a viscosity that is independent of the rate of shear [prEN 13302]

non-newtonian fluid

fluid having a ratio shear stress/shear rate that is not constant

yield stress

the shear stress required to initiate flow. It in SI is expressed as Pa

thixotropic fluid

fluid whose viscosity decreases with time when subjected to shear, if this phenomenon is reversible. If in a thixotropic substance shearing is discontinued for a certain time, its viscosity will again increase.

degree of thixotropy

the degree of thixotropy is determined by the hysteresis method, as the area of the loop formed by the increasing and decreasing shear rates. The area has the dimension of power per unit volume and in SI is expressed as Pa/s.

4 Principle

The sample is introduced, at constant controlled temperature, into an outer cylinder (cup) into which an inner cylinder (bob) is placed. The sample is stressed by rotation of the internal cylinder. The torque measured at different shear rates is proportional to the shear stress. For Newtonian fluids, the dynamic viscosity is determined by the ratio between measured shear stress (Pa) and applied shear rate (s^{-1}). For non-Newtonian fluids the rheological data are calculated by the rheological model that best fits the experimental shear stress/shear rate values. The yield stress is calculated by extrapolating the flow curve to zero shear rate.

5 Equipment

5.1 Coaxial cylinders viscometer

Coaxial cylinders, Searle type viscometer, as represented in Fig. A.1 [prEN 13702-2], with a fixed outer cylinder and a inner rotating cylinder, and with the following minimum capabilities:

- range of shear rates: $1s^{-1}$ to $10^3 s^{-1}$
- range of viscosity: 1 to 10^4 mPa.s
- ratio of the cell radius (outer and inner cylinder): the optimum ratio of the radius shall be selected by laboratory tests according to the physical characteristics of the sample.

In order to avoid wall slip cells with roughened surfaces are chosen.

A stress controlled rotational viscometer can be used to measure with higher precision the yield stress of material and to define the error using common shear rate controlled rotational viscometer.

5.2 Thermostatic bath

Thermostatic bath, electrically heated, to maintain the temperature of the sample constant to within ± 0.2 °C over the temperature range from 10 to 30°C.

5.3 Sieve

The sieve opening for sample pre-treatment shall be selected by laboratory tests.

6 Test sample(s)

As the narrow gap between the outer and the inner cylinders, to avoid clogging phenomenon, coarse particles and lumps of unmixed material must be eliminated by wet sieving of the test sample at the selected sieve.

7 Working instructions [to be tested]

- The standard condition of the test shall be 20 ± 0.2 °C. If any other temperature is used it shall be reported.
- Condition the sample and the instrument at the temperature of 20°C. Mix the sample using the stirring rod and pour it into the cup making the transfer in such a manner that the sample will be worked as little as possible. Lower the rotational cylinder into the sample taking care that no air is trapped under or around.
- Start the motor of the viscometer at the lowest rotational speed and increase the shear rate step by step to a maximum shear rate and in a time interval to be optimised by laboratory tests according to sample physical characteristics.
- Convert the torque values in shear stress values by multiplying the torque values for a constant that depends on the geometry of the apparatus used. Determine the viscosity of newtonian fluid by the ratio of shear stress to shear rate. For non-newtonian fluids plot the shear stress values versus shear rate and calculate the rheological properties by applying the model that best fits the experimental data.
- In case of thixotropic fluids the measurements shall be started with increasing shear rates until the maximum speed is reached and then at decreasing shear rates making further measurements. If the readings at increasing and decreasing shear rate show only random differences, the two readings may be averaged. If a consistent difference is observed, as in the case of thixotropic systems, both values shall be recorded. Prior to measurement, the sample in the viscometer shall have sufficient time to recover any thixotropic structure. This time will depend on the nature of the specific sample and must be optimised. The degree of thixotropy, expressed in Pa/s, can be determined by the hysteresis area formed by the up and down flow curves and represents the power per unit volume necessary to breakdown the internal structure of the sample.

8 Calculations and expression of results

Results of viscosity, yield stress and degree of thixotropy are expressed as an average value of three measurements.

9 Test report

The test report shall include the following informations:

- a) *The standard under consideration and its date of publication (e.g. EN xxxx:2003)*
- b) *Information about the character of the material and the identity of the specific sample(s) to be tested*
- c) *Testing date or period*
- d) *Information on external circumstances*
- e) *All calculation results*
- f) *Identification of the standards used in the total test procedure*
- g) *Any details not specified in this standard or which are optional and any other factor, which may have affected the results.*

Document type: European Standard

Document subtype:

Document stage: CEN Enquiry

Document language: E

- h) *Always finish the report with: 'Where the test is not carried out in accordance with this standard, reference may only be made to EN xxxx:2003 in the report in case all deviations from the procedures prescribed in this standard are indicated in the report stating the reasons for deviation'.*

Annex A
(informative)

Laboratory coaxial cylinders viscometer

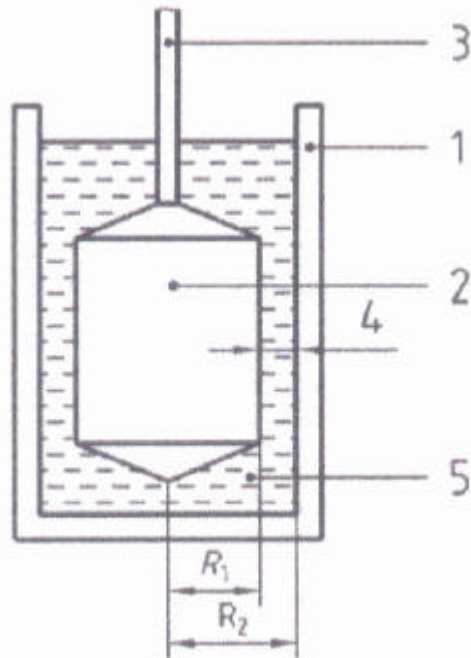

Key

1. Outer cylinder
2. Inner rotating cylinder
3. Spindle
4. Thickness of sample being measured
5. Sample under test

Figure A.1 — Coaxial viscometer (principle)

Bibliography

- [1] P. Battistoni, G. Fava, Maria L. Ruello, "Rheology of sewage sludge (1): Development of a standardised methodology for rheological properties measurements". *Ingegneria Sanitaria*, N°2, pp. 10-19, 1990.
- [2] P. Battistoni, G. Fava, F.Cecchi and P. Pavan, "Rheology of sludge from semi-dry anaerobic digestion of municipal solid waste". *Environmental Technology*, Vol. 12, pp 897-905, 1991.
- [3] J.C. Baudez, "Rheologie et physico-chimie des boues residuaires pateuses pour du stockage et de l'epabdage ". Phd Thesis, Ecole National Du genie rural, des eaux et des forets, Cemagref- Pris -2 April 2001.
- [4] P. Battistoni, G. Fava, C. Stanzini, F. Cecchi and B. Bassetti, "Feed characteristics and digester operative conditions as parameters affecting the rheology of digested municipal solid wastes". *Water Science and Technology*, Vol. 27, N°2, pp 37-45, 1993.
- [5] P. Battistoni, "Pre-treatment, measurements execution procedures and waste characteristics in the rheology of sewage sludges and the digested organic fraction of municipal solid wastes". *Water Science and Technology*, Vol. 36, N°11, pp 33-41, 1997.

Date:

CEN

Secretariat:

Physical properties – Determination of flowability – Field test method by 'flow cone apparatus'

Physikalische Eigenschaften – Bestimmung der Fließfähigkeit – Laborreferenzmethode mit [...]

Propriétés [...] – Détermination de [...] – : [...]

ICS:

Descriptors:

Contents

| | |
|--|----|
| Foreword | 13 |
| Introduction | 14 |
| 1 Scope | 15 |
| 2 Standards and other normative references | 15 |
| 3 Terms and definitions..... | 15 |
| 4 Principle | 16 |
| 5 Equipment | 16 |
| 5.1 Flow cone | 16 |
| 5.2 Ring stand | 16 |
| 5.3 Receiving container..... | 16 |
| 5.4 Level or similar..... | 16 |
| 5.5 Pouring container..... | 16 |
| 5.6 Stopwatch..... | 16 |
| 6 Test sample(s) | 16 |
| 7 Working instructions..... | 16 |
| 8 Calculations and expression of results | 17 |
| 9 Test report..... | 17 |
| Annex A (informative) Flow cone | 18 |
| Bibliography | 19 |

Foreword

This document has been prepared by HORIZONTAL-Committee // CEN/TC /..., "[...]."

This document is currently submitted to the HORIZONTAL Enquiry.

Other parts of this European Standard /HORIZONTAL Standards – Physical Properties are:

[...] - Determination of bulk density;

[...] - Determination of dry matter;

[...] - Determination of total volatile solid;

[...] - Determination of solidity;

[...] - Determination of thixotropic behaviour;

[...] - Determination of piling behaviour;

Introduction

This document is developed in the project 'Horizontal'. It is the result of desk study "**Physical properties – Flowability**" in the project and aims at a **field method** for determining the **flowability** of sludge, soil, treated bio-waste and related wastes by means of the **flow cone apparatus**. After discussion with all parties concerned in CEN and selection of a number of test methods described in this study will be developed further as an modular horizontal method and validated in the project 'Horizontal'.

Until now test methods determining properties of materials were often prepared in Technical Committees (TC's) working on specific products or specific sectors. In those test methods often steps as sampling, extraction, release or other processing, analyses, etc were included. In this approach it was necessary to develop, edit and validate similar procedural steps over and over again for each other product. Consequently this resulted in a lot of duplicate work. To avoid such duplication of work for parts of a testing procedure often was referred to parts of test methods from other TC's. However following problems are often encountered while using references in this way:

- 4) The referenced parts are often not edited in a way that they could easily be referred to,
- 5) the referenced parts are often not validated for the other type of material and
- 6) the updates of such test standards on products might lead to inadequate references.

In the growing amount of product and sector oriented test methods it was recognised that many steps in test procedures are or could be used in test procedures for many products, materials and sectors. It was supposed that, by careful determination of these steps and selection of specific questions within these steps, elements of the test procedure could be described in a way that they can be used for all materials and products or for all materials and products with certain specifications.

Based on this hypothesis a horizontal modular approach is being investigated and developed in the project 'Horizontal'. 'Horizontal' means that the methods can be used for a wide range of materials and products with certain properties. 'Modular' means that a test standard developed in this approach concerns a specific step in a test procedure and not the whole test procedure.

The texts of the chapters [x,x, and x] are normative; chapter [x, x] are informative chapters; annexes are normative or informative, as stated in the top lines of the annexes.

10 Scope

This Part of this European standard specifies a field method for determining the flowability of sludge, soil, treated bio-waste and related wastes by means of the flow cone apparatus.

This Part of this European Standard is applicable to sludge, soil, treated bio-waste and related wastes from:

- storm water handling
- urban wastewater collecting systems
- urban wastewater treatment plants
- treating industrial wastewater similar to urban wastewater (as defined in Directive 91/271/EEC)
- water supply treatment plants
- soils [...]
- treated biowaste [...]
- wastes [...]

This method is also applicable to sludges, soils, treated biowaste and related wastes of other origin.

11 Standards and other normative references

This European Standard incorporates by dated or undated reference, provisions from other publications. These normative references are cited at the appropriate places in the text and the publications are listed hereafter. For dated references, subsequent amendments to or revisions of any of these publications apply to this European Standard only when incorporated in it by amendment or revision. For undated references the latest edition of the publication referred to applies (including amendments).

prEN 14117-2002 DRAFT — Products and systems for the protection and repair of concrete structures - Test method - Determination of viscosity of cementitious injection products.

ASTM C 939 — Standard test method for flow of grout for preplaced-aggregate concrete.

NF P 18-507:1992 — Addition for concrete - Water retention - Method for measurement of fluidity by flowing with the "Cone de MARSH".

NF P 18-358 — Admixtures for concretes, mortar and grouts - Routine grouts for prestressing ducts - Measurement of fluidity and water reduction.

12 Terms and definitions

For the purposes of this Part of this European Standard, the terms and definitions as stated in [...] and the following terms and definitions apply.

flow time

time of efflux of a specified volume of fluid product through the flow cone [prEN 14117]

13 Principle

The time of efflux of a specified volume of the fluid sludge from a standardised flow cone is measured. When efflux time exceeds a pre-determined value (to be evaluated by laboratory tests) the flowability is better determined by cone penetration or extrusion tube viscometer methods.

14 Equipment

14.1 Flow cone

Flow cone provided with a semicircular shaped sieve with opening dimensions **to be optimised**, (Fig.A.1).

The diameter and length of the detectable discharge tube bolted or screwed to the lower part of the cone must be optimised by laboratory tests. The discharge tube should have a ratio length /diameter of approximately 10/1 as a minimum, to reduce the inlet errors.

The body of the discharge tube shall be stainless steel or other essentially non-corroding material.

14.2 Ring stand

Ring stand, or other device, capable of supporting the flow cone in a vertical, steady position 150 ± 10 mm above the upper face of the receiving container.

14.3 Receiving container

Receiving container, which allows the measurement of a volume of 1000 ± 10 ml of the product.

14.4 Level or similar

14.5 Pouring container

Pouring container, which allows the measurement of a volume of product of 1500 ± 15 ml.

14.6 Stopwatch

Stopwatch with a precision of 0.5 s

14.7 Thermometer

Thermometer, with a precision of 0.5°C

15 Test sample(s)

The sample shall be mixed using a stirring rod and introduced into the flow cone through the sieve to eliminate coarse solid particles or lumps of unmixed materials that may cause uneven flow through the discharge tube or stop the flow completely.

16 Working instructions

- The standard condition of the test shall be 20 ± 0.5 °C. If any other temperature is used it shall be reported.
- The flow cone must be firmly mounted in such a manner that it is free of vibrations. The top is levelled to assure vertically. The receiving container is levelled.
- The inside of the flow cone is moistened by filling the cone with water and, 1 min before introducing the sludge, the water is allowed to drain from the cone.
- The sludge is mixed with the stirring rod, the outlet of the discharge tube is closed with a stopper and 1500 ± 15 ml of the sample are introduced into the cone through the sieve; the stopwatch is started and simultaneously the stopper is removed. The watch is stopped when the amount of sludge flowed through the cone is 1000 ± 10 ml.
- The measurements shall be made in triplicate. Before each measurement, the flow cone and receiving container shall be absolutely clear and free from product.

17 Calculations and expression of results

The results of the measurements are expressed as average time of efflux in seconds at the corresponding test temperature.

18 Test report

The test report shall include the following informations:

- i) The standard under consideration and its date of publication (e.g. EN xxxx:2003)*
- j) Information about the character of the material and the identity of the specific sample(s) to be tested*
- k) Testing date or period*
- l) Information on external circumstances*
- m) All calculation results*
- n) Identification of the standards used in the total test procedure*
- o) Any details not specified in this standard or which are optional and any other factor, which may have affected the results.*
- p) Always finish the report with: 'Where the test is not carried out in accordance with this standard, reference may only be made to EN xxxx:2003 in the report in case all deviations from the procedures prescribed in this standard are indicated in the report stating the reasons for deviation'.*

Annex B
(informative)

Flow cone

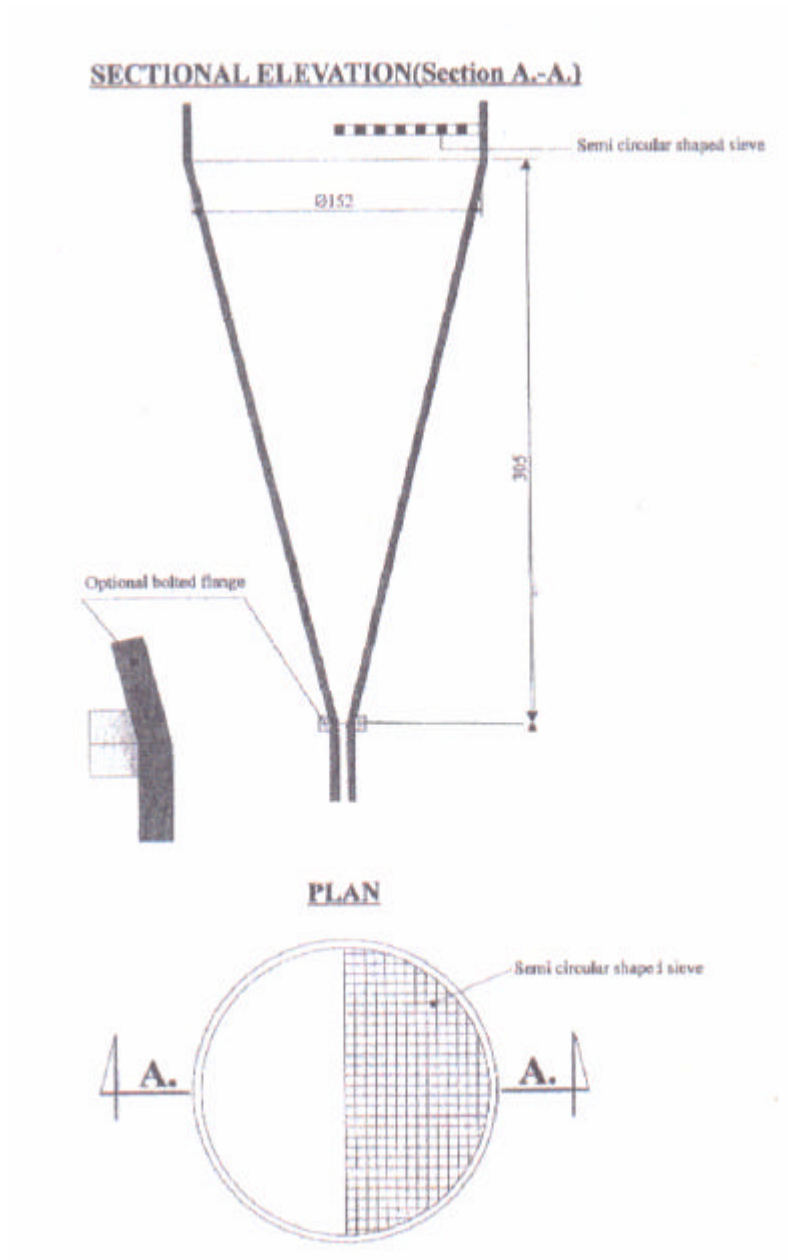

Figure B.1 — Flow cone (dimensions in mm)

Bibliography

[6]

[7]

[8]

[9]

Date:

CEN

Secretariat:

Physical properties – Determination of flowability – Field test method by 'penetration cone apparatus'

Physikalische Eigenschaften – Bestimmung der Fließfähigkeit – Laborreferenzmethode mit [...]

Propriétés [...] – Détermination de [...] – : [...]

ICS:

Descriptors:

Contents

| | |
|---|----|
| Foreword | 22 |
| Introduction | 23 |
| 1 Scope..... | 24 |
| 2 Standards and other normative references..... | 24 |
| 3 Terms and definitions..... | 24 |
| 4 Principle..... | 24 |
| 5 Equipment | 25 |
| 5.1 Penetrometer..... | 25 |
| 5.2 Cup | 25 |
| 5.3 Cone-test rod assembly..... | 25 |
| 5.4 Support plane | 25 |
| 5.5 Stopwatch..... | 25 |
| 5.6 Thermometer | 25 |
| 5.7 Spatula..... | 25 |
| 6 Test sample(s) | 25 |
| 7 Working instructions | 25 |
| 8 Calculations and expression of results | 26 |
| 9 Test report..... | 26 |
| Annex A (informative) Penetration cone apparatus..... | 27 |
| Bibliography | 28 |

Foreword

This document has been prepared by HORIZONTAL-Committee // CEN/TC /..., "[...]."

This document is currently submitted to the HORIZONTAL Enquiry.

Other parts of this European Standard /HORIZONTAL Standards – Physical Properties are:

[...] - Determination of bulk density;

[...] - Determination of dry matter;

[...] - Determination of solidity;

[...] - Determination of thixotropic behaviour;

[...] - Determination of piling behaviour;

Introduction

This document is developed in the project 'Horizontal'. It is the result of desk study "Physical properties – Flowability" in the project and aims at a field method for determining the flowability of sludge, soil, treated bio-waste and related wastes by means of the penetration cone apparatus. After discussion with all parties concerned in CEN and selection of a number of test methods described in this study will be developed further as an modular horizontal method and validated in the project 'Horizontal'.

Until now test methods determining properties of materials were often prepared in Technical Committees (TC's) working on specific products or specific sectors. In those test methods often steps as sampling, extraction, release or other processing, analyses, etc were included. In this approach it was necessary to develop, edit and validate similar procedural steps over and over again for each other product. Consequently this resulted in a lot of duplicate work. To avoid such duplication of work for parts of a testing procedure often was referred to parts of test methods from other TC's. However following problems are often encountered while using references in this way:

- 7) The referenced parts are often not edited in a way that they could easily be referred to,
- 8) the referenced parts are often not validated for the other type of material and
- 9) the updates of such test standards on products might lead to inadequate references.

In the growing amount of product and sector oriented test methods it was recognised that many steps in test procedures are or could be used in test procedures for many products, materials and sectors. It was supposed that, by careful determination of these steps and selection of specific questions within these steps, elements of the test procedure could be described in a way that they can be used for all materials and products or for all materials and products with certain specifications.

Based on this hypothesis a horizontal modular approach is being investigated and developed in the project 'Horizontal'. 'Horizontal' means that the methods can be used for a wide range of materials and products with certain properties. 'Modular' means that a test standard developed in this approach concerns a specific step in a test procedure and not the whole test procedure.

The texts of the chapters [x,x, and x] are normative; chapter [x, x] are informative chapters; annexes are normative or informative, as stated in the top lines of the annexes.

19 Scope

This Part of this European standard specifies a field method for determining the flowability of sludge, soil, treated bio-waste and related wastes by means of the penetration cone apparatus.

This Part of this European Standard is applicable to sludge, soil, treated bio-waste and related wastes from:

- *storm water handling*
- *urban wastewater collecting systems*
- *urban wastewater treatment plants*
- *treating industrial wastewater similar to urban wastewater (as defined in Directive 91/271/EEC)*
- *water supply treatment plants*
- *soils [...]*
- *treated biowaste [...]*
- *wastes [...]*

This method is also applicable to sludges, soils, treated biowaste and related wastes of other origin.

20 Standards and other normative references

This European Standard incorporates by dated or undated reference, provisions from other publications. These normative references are cited at the appropriate places in the text and the publications are listed hereafter. For dated references, subsequent amendments to or revisions of any of these publications apply to this European Standard only when incorporated in it by amendment or revision. For undated references the latest edition of the publication referred to applies (including amendments).

ASTM D 2884:2002 — Standard test method for yield stress of heterogeneous propellants by cone penetration method.

21 Terms and definitions

For the purposes of this Part of this European Standard, the terms and definitions as stated in [ASTM D 2884] and the following terms and definitions apply.

sample penetration

the depth, in tenths of a millimetre that a standard cone penetrates the sample under prescribed conditions of weight, time and temperature.

22 Principle

The penetration is determined by releasing the cone-test rod assembly from the apparatus and measuring the distance in tenths of millimetres that the cone penetrates vertically into a specimen of the material for 5 s. The cone will be essentially at rest in less than this time, so the exact timing is not critical.

23 Equipment

23.1 Penetrometer

The cone assembly shall be adjustable to enable accurate placement of the cone on the level surface of the sample while maintaining a zero reading on the indicator. The instrument shall be provided with levelling screws to maintain the cone in a vertical position.

23.2 Cup

The cup shall be made of non-corroding, non-absorbent material, and shall be 76.2 mm in inside diameter and 63.5 mm in deep as shown in Fig. A.1. The conversion of penetration to yield stress has not been corrected for the displacement of the sample by the submerged portion of the cone. For this reason cup diameter is critical and any deviation from the standard measurements must be reported as non-standard condition.

23.3 Cone-test rod assembly

The standard cone-test rod assembly has a total mass of 30 g, **the experimental work must define the optimum height according to the material used and sample characteristics**. The cone is made of magnesium and has the dimensions shown in Fig. A.2. If the material from which the cone is made is other than magnesium slippage along the cone surface can take place with surfaces, which are highly lipophilic. The rod is made of aluminium.

23.4 Support plane

The penetrometer shall be mounted on a stable, free of vibrations support plane.

23.5 Stopwatch

Stopwatch, with a precision of 0.5 s

23.6 Thermometer

Thermometer, with a precision of 0.5 °C

23.7 Spatula

Corrosion-resistant, square-ended, having a stiff blade 30 mm wide and at least 150 mm long.

24 Test sample(s)

Sufficient test specimen (at least 450 g) to overfill the cup shall be required.

25 Working instructions

- The standard condition of the test shall be 20 ± 0.5 °C. If any other temperature is used it shall be reported.
- Level the apparatus to assure vertically. Overfill the cup with the sample making the transfer in such a manner that the sample will be worked as little as possible. Jar the container to drive out trapped air and pack the sample with the spatula, with as little manipulations as possible. Scrape out the excess sample extending above the rim by moving the blade of the spatula.
- Clean the penetrometer cone carefully before the test. Do not use grease oil on the test rod as they can cause drag on the assembly.
- Place the cup on the penetrometer table, making certain that it cannot teeter. Set the mechanism to hold the cone in the zero position, and adjust the apparatus carefully so that the tip of the cone just touches the surface at the centre of the test sample. Release the test rod rapidly, allow it to drop for 5 s and read the penetration from the indicator in tenths of mm.

Document type: European Standard

Document subtype:

Document stage: CEN Enquiry

Document language: E

If the penetration exceeds 420 tenths of mm, the sample will overflow into the cone. This invalidates the test and the sample shall be reported as too soft.

- In order to reduce errors the measurements shall be made in triplicate, care being taken to have the cup completely filled and the cone clean.

26 Calculations and expression of results

The three tests results shall be averaged and used to calculate the yield stress (Γ_0) in Pa as follows:

$$\Gamma_0 = \frac{9.81(30 - (1.047 \times 10^{-6})(P - 107.4)^3 d - 0.198d)}{4.44 \times 10^{-4}(P - 107.4)^2 + 1.260}$$

where:

P = penetration, tenths of mm

D = density g/cm³

The yield stress is the weight of the 30 g mass cone-test rod assembly in Newton, corrected for the buoyancy, divided by the calculated wetted area of the cone (that is, the area of the cone in contact with the sample after 5 s drop period).

27 Test report

The test report shall include the following informations:

- q) *The standard under consideration and its date of publication (e.g. EN xxxx:2003)*
- r) *Information about the character of the material and the identity of the specific sample(s) to be tested*
- s) *Testing date or period*
- t) *Information on external circumstances*
- u) *All calculation results*
- v) *Identification of the standards used in the total test procedure*
- w) *Any details not specified in this standard or which are optional and any other factor, which may have affected the results.*
- x) *Always finish the report with: 'Where the test is not carried out in accordance with this standard, reference may only be made to EN xxxx:2003 in the report in case all deviations from the procedures prescribed in this standard are indicated in the report stating the reasons for deviation'.*

Annex C (informative)

Penetration cone apparatus

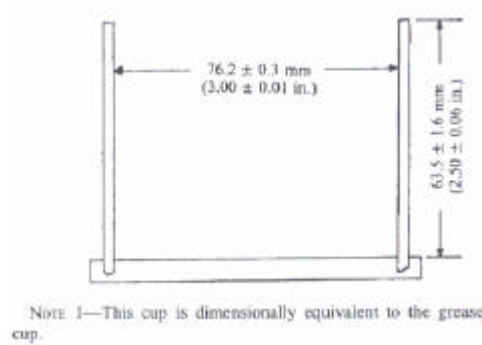

Figure C.1 — Penetrometer cup

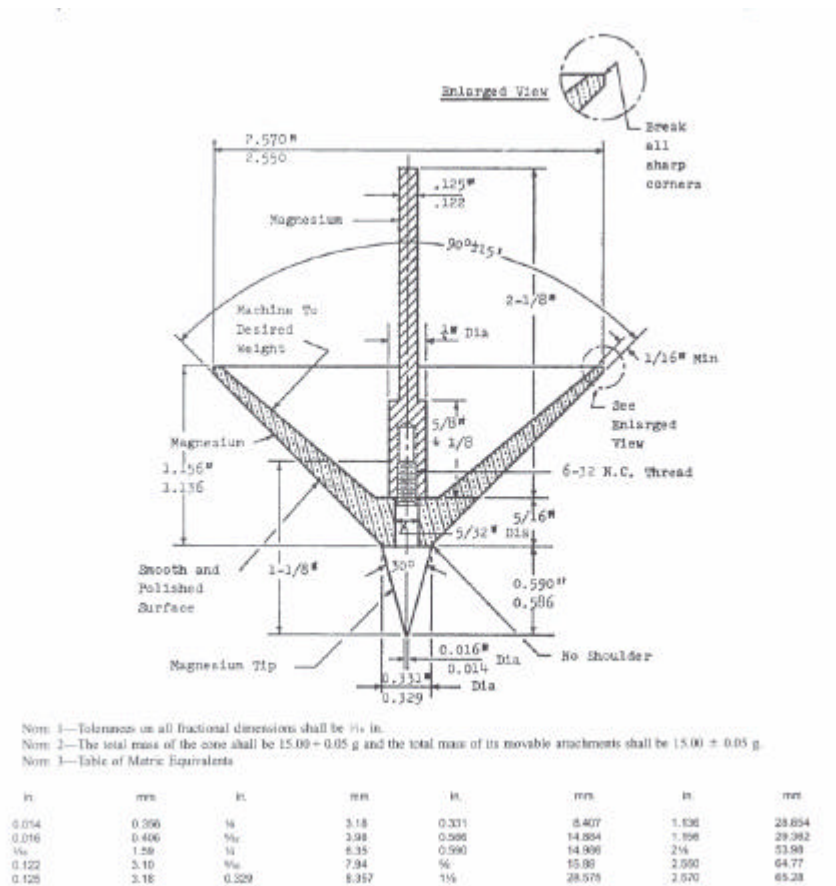

Figure C.2 — Magnesium penetrometer cone

Bibliography

Date:

CEN

Secretariat:

Physical properties – Determination of flowability – Field test method by 'extrusion tube viscometer (kasumeter)'

Physikalische Eigenschaften – Bestimmung der Fließfähigkeit – Laborreferenzmethode mit [...]

Propriétés [...] – Détermination de [...] – : [...]

ICS:

Descriptors:

Contents

| | |
|---|----|
| Foreword | 31 |
| Introduction | 32 |
| 1 Scope | 33 |
| 2 Standards and other normative references | 33 |
| 3 Terms and definitions..... | 33 |
| 4 Principle | 33 |
| 5 Equipment | 33 |
| 5.1 Extrusion apparatus | 33 |
| 5.2 Tripod | 34 |
| 5.3 Pouring container..... | 34 |
| 5.4 Thermometer..... | 34 |
| 6 Test sample(s) | 34 |
| 7 Working instructions..... | 34 |
| 8 Calculations and expression of results | 34 |
| 9 Test report..... | 34 |
| Annex A (informative) Extrusion tube viscometer (kasumeter) | 36 |
| Bibliography | 37 |

Foreword

This document has been prepared by HORIZONTAL-Committee // CEN/TC /..., "[...]."

This document is currently submitted to the HORIZONTAL Enquiry.

Other parts of this European Standard /HORIZONTAL Standards – Physical Properties are:

[...] - Determination of bulk density;

[...] - Determination of dry matter;

[...] - Determination of solidity;

[...] - Determination of thixotropic behaviour;

[...] - Determination of piling behaviour;

Introduction

This document is developed in the project 'Horizontal'. It is the result of desk study "Physical properties – Flowability" in the project and aims at a field method for determining the flowability of sludge, soil, treated bio-waste and related wastes by means of the extrusion tube viscometer. After discussion with all parties concerned in CEN and selection of a number of test methods described in this study will be developed further as an modular horizontal method and validated in the project 'Horizontal'.

Until now test methods determining properties of materials were often prepared in Technical Committees (TC's) working on specific products or specific sectors. In those test methods often steps as sampling, extraction, release or other processing, analyses, etc were included. In this approach it was necessary to develop, edit and validate similar procedural steps over and over again for each other product. Consequently this resulted in a lot of duplicate work. To avoid such duplication of work for parts of a testing procedure often was referred to parts of test methods from other TC's. However following problems are often encountered while using references in this way:

- 10) The referenced parts are often not edited in a way that they could easily be referred to,
- 11) the referenced parts are often not validated for the other type of material and
- 12) the updates of such test standards on products might lead to inadequate references.

In the growing amount of product and sector oriented test methods it was recognised that many steps in test procedures are or could be used in test procedures for many products, materials and sectors. It was supposed that, by careful determination of these steps and selection of specific questions within these steps, elements of the test procedure could be described in a way that the can be used for all materials and products or for all materials and products with certain specifications.

Based on this hypothesis a horizontal modular approach is being investigated and developed in the project 'Horizontal'. 'Horizontal' means that the methods can be used for a wide range of materials and products with certain properties. 'Modular' means that a test standard developed in this approach concerns a specific step in a test procedure and not the whole test procedure.

The texts of the chapters [x,x, and x] are normative; chapter [x, x] are informative chapters; annexes are normative or informative, as stated in the top lines of the annexes.

28 Scope

This Part of this European standard specifies a field method for determining the flowability of sludge, soil, treated bio-waste and related wastes by means of the extrusion tube viscometer.

This Part of this European Standard is applicable to sludge, soil, treated bio-waste and related wastes from:

- *storm water handling*
- *urban wastewater collecting systems*
- *urban wastewater treatment plants*
- *treating industrial wastewater similar to urban wastewater (as defined in Directive 91/271/EEC)*
- *water supply treatment plants*
- *soils [...]*
- *treated biowaste [...]*
- *wastes [...]*

This method is also applicable to sludges, soils, treated biowaste and related wastes of other origin.

29 Standards and other normative references

This European Standard is not based on pre-existing standards. The publication reference is reported hereafter [1].

30 Terms and definitions

For the purposes of this Part of this European Standard, the following terms and definitions apply.

yield stress

the shear stress to overcome to initiate flow

31 Principle

The yield stress is determined by the measurement of the height of the sludge remaining in the cylinder when the flow through the standardised discharge pipe, fitted at the bottom of the container, stops. The above height value allows the corresponding value of yield stress to be calculated through the flow equation.

32 Equipment

32.1 Extrusion apparatus

The extrusion tube viscometer (Kasumeter) of Fig. A.1, consists of a cylindrical acrylic container, 100 mm in inside diameter and 350 mm in deep, to which calibrated pipes 200 mm in length and different inside diameters (2.5, 5, 10, 16, 20 mm) are fitted at the bottom. The apparatus shall be provided of an internal scale graduated in mm to measure the height of the sludge remaining in the cylinder at the end of the test.

32.2 Tripod

The apparatus shall be mounted on a stable, free of vibrations tripod provided with levelling screws and a bubble level to adjust the cylinder in a vertical position.

32.3 Pouring container

Pouring container of appropriate capacity.

32.4 Thermometer

Thermometer, with a precision of 0.5 °C

33 Test sample(s)

Sufficient test sample to fill up the apparatus (about 3 litres) shall be required.

The presence of coarse particles or lumps of aggregate in the suspension can cause clogging phenomena, particularly when using small diameter pipe. If necessary, the apparatus shall be provided with a suitable sieve for a sample pre-treatment.

34 Working instructions

- The standard condition of the test shall be 20 ± 0.5 °C. If any other temperature is used it shall be reported.
- Level the apparatus to assure vertically. Fill up the cylinder with the sample by keeping closed the end side of the calibrated tube and by avoiding the presence of air bubbles. Make the transfer in such a manner that the sample will be worked as little as possible. The selection of the optimum tube diameter shall be carried out by laboratory tests.
- Let the flow start from the discharge tube until it becomes discontinuous. At this time measure the height of the sludge remaining in the cylinder.

35 Calculations and expression of results

By measuring the height of the sludge remaining in the cylinder at the end of continuous flow, the yield stress (Γ_0) can be calculated through the following equation:

$$\Gamma_0 = \frac{3}{8} \times \frac{\rho g h r}{l}$$

where:

ρ = sludge density (kg/m^3)

g = gravity acceleration (m/s^2)

h = height of the suspension remaining in the cylinder (m)

r = pipe radius (m)

l = pipe length (m)

Γ_0 = yield stress (Pa)

36 Test report

The test report shall include the following informations:

- y) *The standard under consideration and its date of publication (e.g. EN xxxx:2003)*
- z) *Information about the character of the material and the identity of the specific sample(s) to be tested*
 - aa) *Testing date or period*
 - bb) *Information on external circumstances*

- cc) *All calculation results*
- dd) *Identification of the standards used in the total test procedure*
- ee) *Any details not specified in this standard or which are optional and any other factor, which may have affected the results.*
- ff) *Always finish the report with: 'Where the test is not carried out in accordance with this standard, reference may only be made to EN xxxx:2003 in the report in case all deviations from the procedures prescribed in this standard are indicated in the report stating the reasons for deviation'.*

Annex D
(informative)

Extrusion tube viscometer (kasometer)

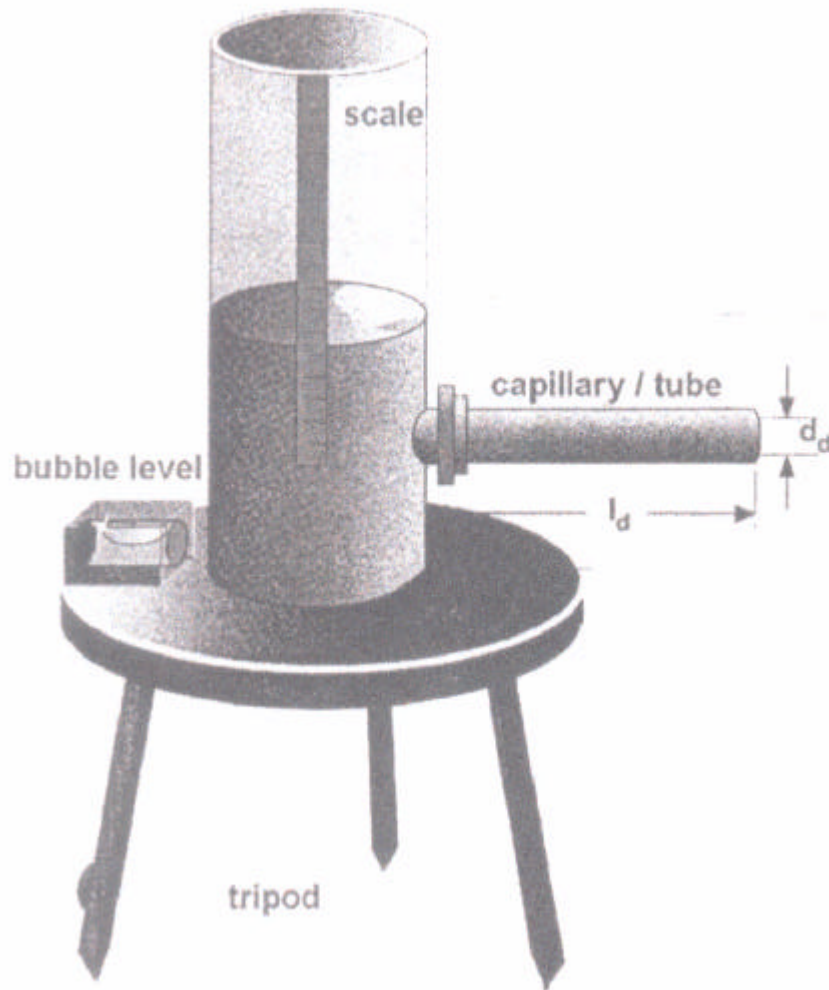

Figure D.1 — Extrusion tube viscometer

Bibliography

- [10] Von B. Schulze, J. I. Braunschwalm,. Neuartiges baustellen-meßgerät zur bestimmung der fließgrenze von suspensionen. Geotechnik 14, 125-131, 1991.
- [11] L . Spinosa, V. Lotito, "A simple method for evaluating sludge yield stress", Advances in Environmental Research, N° 7, pp 655-659, 2003.
- [12] CEN/TC308/WG1/TG3 - N12, "Measurements of sludge consistency".

Date:

CEN

Secretariat:

Physical properties – Determination of flowability – Field test method by 'inclined plane'

Physikalische Eigenschaften – Bestimmung der Fließfähigkeit – Laborreferenzmethode mit [...]

Propriétés [...] – Détermination de [...] – : [...]

ICS:

Descriptors:

Contents

| | |
|---|----|
| Foreword | 40 |
| Introduction | 41 |
| 1 Scope..... | 42 |
| 2 Standards and other normative references..... | 42 |
| 3 Terms and definitions..... | 42 |
| 4 Principle..... | 42 |
| 5 Equipment | 42 |
| 5.1 Inclined plane | 42 |
| 5.2 Mounting..... | 43 |
| 5.3 Ruler | 43 |
| 5.4 Stopwatch..... | 43 |
| 5.5 Thermometer | 43 |
| 6 Test sample(s) | 43 |
| 7 Working instructions | 43 |
| 8 Calculations and expression of results | 43 |
| 9 Test report | 44 |
| Annex A (informative) Inclined plane..... | 45 |
| Bibliography | 46 |

Foreword

This document has been prepared by HORIZONTAL-Committee // CEN/TC /..., "[...]."

This document is currently submitted to the HORIZONTAL Enquiry.

Other parts of this European Standard /HORIZONTAL Standards – Physical Properties are:

[...] - Determination of bulk density;

[...] - Determination of dry matter;

[...] - Determination of solidity;

[...] - Determination of thixotropic behaviour;

[...] - Determination of piling behaviour;

Introduction

This document is developed in the project 'Horizontal'. It is the result of desk study "Physical properties – Flowability" in the project and aims at a field method for determining the flowability of sludge, soil, treated bio-waste and related wastes by means of the inclined plane test. After discussion with all parties concerned in CEN and selection of a number of test methods described in this study will be developed further as an modular horizontal method and validated in the project 'Horizontal'.

Until now test methods determining properties of materials were often prepared in Technical Committees (TC's) working on specific products or specific sectors. In those test methods often steps as sampling, extraction, release or other processing, analyses, etc were included. In this approach it was necessary to develop, edit and validate similar procedural steps over and over again for each other product. Consequently this resulted in a lot of duplicate work. To avoid such duplication of work for parts of a testing procedure often was referred to parts of test methods from other TC's. However following problems are often encountered while using references in this way:

- 13) The referenced parts are often not edited in a way that they could easily be referred to,
- 14) the referenced parts are often not validated for the other type of material and
- 15) the updates of such test standards on products might lead to inadequate references.

In the growing amount of product and sector oriented test methods it was recognised that many steps in test procedures are or could be used in test procedures for many products, materials and sectors. It was supposed that, by careful determination of these steps and selection of specific questions within these steps, elements of the test procedure could be described in a way that the can be used for all materials and products or for all materials and products with certain specifications.

Based on this hypothesis a horizontal modular approach is being investigated and developed in the project 'Horizontal'. 'Horizontal' means that the methods can be used for a wide range of materials and products with certain properties. 'Modular' means that a test standard developed in this approach concerns a specific step in a test procedure and not the whole test procedure.

The texts of the chapters [x,x, and x] are normative; chapter [x, x] are informative chapters; annexes are normative or informative, as stated in the top lines of the annexes.

37 Scope

This Part of this European standard specifies a field method for determining the flowability of sludge, soil, treated bio-waste and related wastes by means of inclined plane test.

This Part of this European Standard is applicable to sludge, soil, treated bio-waste and related wastes from:

- storm water handling
- urban wastewater collecting systems
- urban wastewater treatment plants
- treating industrial wastewater similar to urban wastewater (as defined in Directive 91/271/EEC)
- water supply treatment plants
- soils [...]
- treated biowaste [...]
- wastes [...]

This method is also applicable to sludges, soils, treated biowaste and related wastes of other origin.

38 Standards and other normative references

This European Standard is not based on pre-existing standards. The publication reference is reported hereafter.

Philippe Coussot, Stephane Boyer "Determination of yield stress fluid behaviour from inclined plane test" Rheological Acta 34:534-543 (1995).

39 Terms and definitions

For the purposes of this Part of this European Standard, the following terms and definitions apply.

yield stress

the shear stress to overcome to initiate flow

40 Principle

The yield stress is determined by the measurement of the final depth of the sludge remaining on the inclined channel after the end of the flow gravity-induced emptying of a dam placed upstream. The above height value corresponding to rest state allows the value of yield stress to be calculated assuming that the mean wall shear stress for the flow of a fluid in a channel is equal to the fluid yield stress.

41 Equipment

41.1 Inclined plane

The inclined plane consists of an open rectangular channel with a slope ranging from 10 to 30° and a width ranging from 5 to 25 cm. The bottom surface is plywood. The channel must be equipped with a damming system located upstream fitted with a bottom valve.

41.2 Mounting

The apparatus shall be mounted on a stable, free of vibrations mounting provided with a system capable of changing the inclination of the channel and a scale for measuring the inclination angle.

41.3 Ruler

Ruler or other measuring stick graduated in mm to measure the height of the sludge remaining on the channel at the end of the flow.

41.4 Stopwatch

Stopwatch with a precision of 0.5 s

41.5 Thermometer

Thermometer, with a precision of 0.5°C

42 Test sample(s)

Sufficient test sample to fill up the apparatus shall be required.

This method can be applied to the determination of yield stress of industrial or natural viscoplastic coarse suspensions. For fluids which show apparent thixotropic properties the results are significantly dependent on previous flow history, and thus on the complete experimental conditions (procedure for mass addition, time of rest before starting test, etc.) that must be accurately standardised.

43 Working instructions

- The standard condition of the test shall be 20 ± 0.5 °C. If any other temperature is used it shall be reported.
- Incline the channel to the selected slope ranging from 10 to 30°. The selection of the optimum slope value shall be carried out by laboratory tests.
- Fill the damming system with the material. making the transfer in such a manner that the sample will be worked as little as possible. Progressively open the bottom valve (gate) so that the fluid can slowly flow downstream, see Fig. A1. The total volume supplied must be large enough for fluid to reach the downstream edge of the channel. After the complete opening of the bottom valve, the fluid will flow along the channel and will fall down along the downstream vertical channel edge. To avoid any influence by this latter flow, regularly clean the material stopped there.
- Wait a time long enough for the fluid to appear completely stopped in the channel, see Fig. A2. In general the fluid stops in a time comprised between 15 and 40 min.
- Measure the fluid depth (h) in the middle part of the flow at least as far as 20 cm from the tips.

44 Calculations and expression of results

By measuring the height of the sludge in the middle part of the channel at the end of continuous flow, the yield stress (τ_0) can be calculated through the following equation:

$$G_0 = \frac{\rho g h (\sin i) L}{L + 2h}$$

where:

ρ = sludge density (kg/m³)

g = gravity acceleration (m/s²)

h = depth of the suspension corresponding to rest (m)

Document type: European Standard

Document subtype:

Document stage: CEN Enquiry

Document language: E

L = channel width (m)

σ_0 = yield stress (Pa)

45 Test report

The test report shall include the following informations:

- gg) The standard under consideration and its date of publication (e.g. EN xxxx:2003)*
- hh) Information about the character of the material and the identity of the specific sample(s) to be tested*
- ii) Testing date or period*
- jj) Information on external circumstances*
- kk) All calculation results*
- ll) Identification of the standards used in the total test procedure*
- mm) Any details not specified in this standard or which are optional and any other factor, which may have affected the results.*
- nn) Always finish the report with: 'Where the test is not carried out in accordance with this standard, reference may only be made to **EN xxxx:2003** in the report in case all deviations from the procedures prescribed in this standard are indicated in the report stating the reasons for deviation'.*

Annex E (informative)

Inclined plane

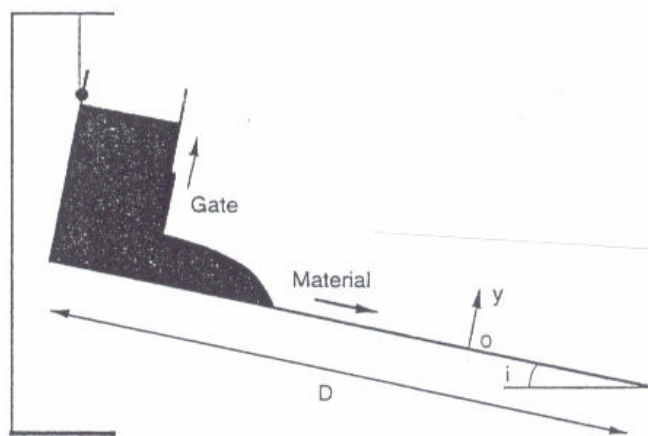

Figure 1 — Flow start after gate opening

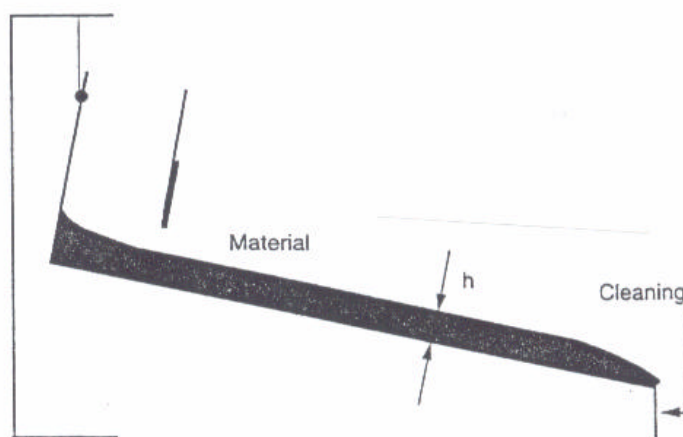

Figure 2 — Final fluid position after stoppage

Bibliography

- [13] Coussot P. "Steady laminar flow of concentrated mud suspensions in open channel" J. Hydr. Res., Vol. 32, pp 535-559, 1994.
- [14] De Kee D., Chhabra RP., Powley MB., Roy S., " Flow of viscoplastic fluids on an inclined plane: Evaluation of yield stress. Chem. Eng. Comm., Vol. 96, pp 229-239, 1990.

Date:

CEN

Secretariat:

Physical properties – Determination of flowability – Field test method by 'modified slump test'

Physikalische Eigenschaften – Bestimmung der Fließfähigkeit – Laborreferenzmethode mit [...]

Propriétés [...] – Détermination de [...] – : [...]

ICS:

Descriptors:

Contents

| | |
|--|----|
| Foreword | 49 |
| Introduction | 50 |
| 1 Scope | 51 |
| 2 Standards and other normative references | 51 |
| 3 Terms and definitions..... | 51 |
| 4 Principle | 51 |
| 5 Equipment | 51 |
| 5.1 PVC cylinder..... | 51 |
| 5.2 PVC plate..... | 52 |
| 5.3 PVC hat..... | 52 |
| 5.4 Vertical axis..... | 52 |
| 5.5 Stopwatch..... | 52 |
| 5.6 Thermometer..... | 52 |
| 6 Test sample(s) | 52 |
| 7 Working instructions..... | 52 |
| 8 Calculations and expression of results | 52 |
| 9 Test report..... | 53 |
| (informative) Modified slump test | 54 |
| Bibliography | 55 |

Foreword

This document has been prepared by HORIZONTAL-Committee // CEN/TC /..., "[...]."

This document is currently submitted to the HORIZONTAL Enquiry.

Other parts of this European Standard /HORIZONTAL Standards – Physical Properties are:

[...] - Determination of bulk density;

[...] - Determination of dry matter;

[...] - Determination of solidity;

[...] - Determination of thixotropic behaviour;

[...] - Determination of piling behaviour;

Introduction

This document is developed in the project 'Horizontal'. It is the result of desk study "Physical properties – Flowability" in the project and aims at a field method for determining the flowability of sludge, soil, treated bio-waste and related wastes by means of the modified slump test. After discussion with all parties concerned in CEN and selection of a number of test methods described in this study will be developed further as an modular horizontal method and validated in the project 'Horizontal'.

Until now test methods determining properties of materials were often prepared in Technical Committees (TC's) working on specific products or specific sectors. In those test methods often steps as sampling, extraction, release or other processing, analyses, etc were included. In this approach it was necessary to develop, edit and validate similar procedural steps over and over again for each other product. Consequently this resulted in a lot of duplicate work. To avoid such duplication of work for parts of a testing procedure often was referred to parts of test methods from other TC's. However following problems are often encountered while using references in this way:

- 16) The referenced parts are often not edited in a way that they could easily be referred to,
- 17) the referenced parts are often not validated for the other type of material and
- 18) the updates of such test standards on products might lead to inadequate references.

In the growing amount of product and sector oriented test methods it was recognised that many steps in test procedures are or could be used in test procedures for many products, materials and sectors. It was supposed that, by careful determination of these steps and selection of specific questions within these steps, elements of the test procedure could be described in a way that the can be used for all materials and products or for all materials and products with certain specifications.

Based on this hypothesis a horizontal modular approach is being investigated and developed in the project 'Horizontal'. 'Horizontal' means that the methods can be used for a wide range of materials and products with certain properties. 'Modular' means that a test standard developed in this approach concerns a specific step in a test procedure and not the whole test procedure.

The texts of the chapters [x,x, and x] are normative; chapter [x, x] are informative chapters; annexes are normative or informative, as stated in the top lines of the annexes.

46 Scope

This Part of this European standard specifies a field method for determining the flowability of sludge, soil, treated bio-waste and related wastes by means of the modified slump test.

This Part of this European Standard is applicable to sludge, soil, treated bio-waste and related wastes from:

- *storm water handling*
- *urban wastewater collecting systems*
- *urban wastewater treatment plants*
- *treating industrial wastewater similar to urban wastewater (as defined in Directive 91/271/EEC)*
- *water supply treatment plants*
- *soils [...]*
- *treated biowaste [...]*
- *wastes [...]*

This method is also applicable to sludges, soils, treated biowaste and related wastes of other origin.

47 Standards and other normative references

This European Standard is not based on pre-existing standards. The publication reference is reported hereafter.

Jean-Christophe Baudez, Frederic Chabot, Philippe Coussot, "Rheological interpretation of the slump test" Applied Rheology, pp 133-141, May/June, (2002).

48 Terms and definitions

For the purposes of this Part of this European Standard, the following terms and definitions apply.

yield stress

the shear stress to overcome to initiate flow

49 Principle

The yield stress of pasty materials is determined by the measurement of the final height loss of a volume of a fluid contained in a PVC cylinder suddenly left flowing on a horizontal surface by rapidly lifting the cylinder. Fluids with high values of yield stress (of the order of several hundreds of Pascal) can be analysed by putting a cylindrical hat on the top of the sample in which several masses can be added. Adding a mass is equivalent to consider a sample cylinder of increased height.

50 Equipment

50.1 PVC cylinder

The sample is moulded in a 125 mm diameter PVC cylinder.

(E)

50.2 PVC plate

A large PVC plate is used as bottom surface. The plate can be covered with different surface types: naked plate (PVC surface), sand papers, or PVC with a thin layer of oil.

50.3 PVC hat

For sample with high yield stress value a 110 mm diameter PVC hat is used. The hat is put on the sample, and kept horizontal by means of a vertical axis along which it can easily slide. On the hat various masses are added, (initial mass 100 g), see Fig. A.1.

50.4 Vertical axis

Vertical axis graduated in mm to measure the height of the sample before and after release.

50.5 Stopwatch

Stopwatch with a precision of 0.5 s

50.6 Thermometer

Thermometer, with a precision of 0.5°C

51 Test sample(s)

Sufficient test sample to fill up the cylinder shall be required.

This method can be applied to the determination of yield stress of industrial or natural viscoplastic coarse suspensions. For fluids which show apparent thixotropic properties the results are significantly dependent on previous flow history, and thus on the complete experimental conditions (procedure for mass addition, time of rest before starting test, etc.) that must be accurately standardised.

52 Working instructions

- The standard condition of the test shall be 20 ± 0.5 °C. If any other temperature is used it shall be reported.
- Fill the cylinder with the material, using a spoon in order to limit the voids, making the transfer in such a manner that the sample will be worked as little as possible. For fluids with high stress values put the hat on the cylinder and charge the hat with the selected mass, see Fig. A.2 left.
- Lift rapidly the cylinder and left the sample flowing on the plate, see Fig. A.2 right.
- Measure the height of the deformed material at the end of the motion (generally after 10-30 min) by using the graduated axis.

53 Calculations and expression of results

By measuring the height of the deformed sample at the end of the motion, the yield stress can be calculated from the slump s through the following equation:

$$s = H + z_0 - \frac{2t_0}{rg} \left(1 + \ln \left(\frac{rg(H + z_0)}{2t_0} \right) \right)$$

where:

s = final height loss of the sample (m)

ρ = sludge density (kg/m^3)

g = gravity acceleration (m/s^2)

H = height of the cylinder (m)

z_0 = increased height of the cylinder due to the additional mass $m_0 = \frac{m_0}{r\rho R^2}$

m_0 = additional mass (kg)

R = radius of the cylinder (m)

σ_0 = yield stress (Pa)

The yield stress can be determined from the above equation graphically or with a spreadsheet.

54 Test report

The test report shall include the following informations:

oo) The standard under consideration and its date of publication (e.g. EN xxxx:2003)

pp) Information about the character of the material and the identity of the specific sample(s) to be tested

qq) Testing date or period

rr) Information on external circumstances

ss) All calculation results

tt) Identification of the standards used in the total test procedure

uu) Any details not specified in this standard or which are optional and any other factor, which may have affected the results.

vv) Always finish the report with: 'Where the test is not carried out in accordance with this standard, reference may only be made to EN xxxx:2003 in the report in case all deviations from the procedures prescribed in this standard are indicated in the report stating the reasons for deviation'.

(E)

Annex F (informative)

Modified slump test

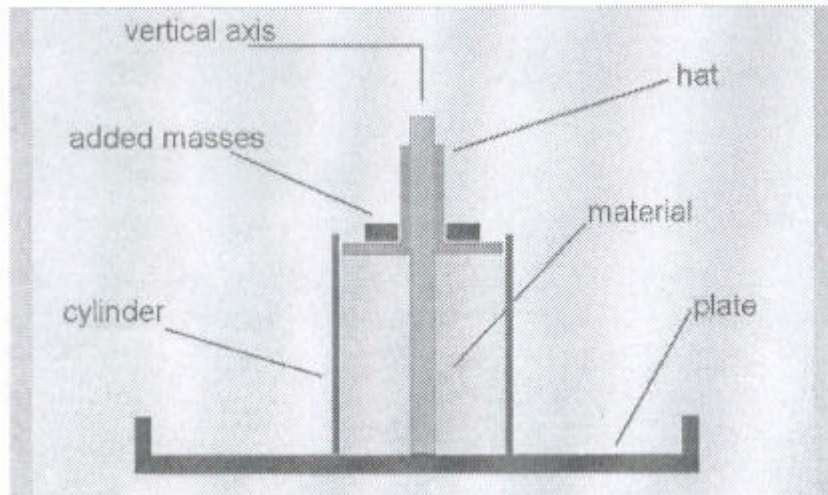

Figure 1 — Detailed scheme of modified slump test

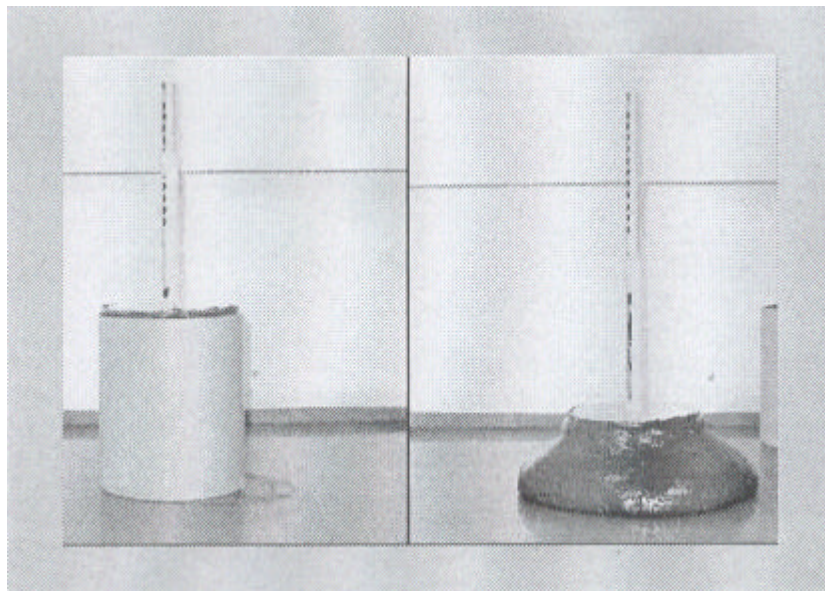

Figure 2 — View of the modified slump test

(left): with the outer cylinder before material release; (right): after material release

Bibliography

- [15] Pashias N, Boger DV, Summers J, Glenister DJ: A fifty cent rheometer for yield stress measurement, *J. Rheol.* 40 (1996) 1179-1189.