

**CEN/TC**

Date: 2003-08

**TC WI**

CEN/TC

Secretariat:

## **Determination of adsorbable organically bound halogens (AOX) — Solid materials**

*Einführendes Element — Haupt-Element — Ergänzendes Element*

*Élément introductif — Élément central — Élément complémentaire*

ICS:

Descriptors:

Document type: European Standard  
Document subtype:  
Document stage: Working Document  
Document language: E

C:\user\Texts\NORMALIS\TC308\HORIZONTAL\contracts\Reports\AOX standard draft2.doc STD Version 2.1a (20020903)

## Contents

Page

Introduction.....	3
1 Scope .....	5
2 Normative references .....	5
3 Definitions .....	5
4 Principle.....	5
5 Interferences .....	5
6 Reagents.....	6
7 Apparatus .....	7
7.1 Apparatus for combustion and detection .....	7
7.2 Equipment for adsorption .....	7
7.3 Equipment for sample preparation .....	7
8 Sampling and sample pre-treatment .....	8
8.1 Sampling.....	8
8.2 Sample pre-treatment.....	8
9 Procedure .....	8
9.1 Adsorption and inorganic halide removal.....	8
9.2 Combustion.....	9
9.3 Calibration .....	9
9.3.1 General.....	9
9.3.2 Calibration of the entire system .....	9
9.3.3 Calibration of argentometric measuring device .....	10
9.4 Blank determination.....	11
9.5 Quality Assurance of the overall procedure.....	11
9.5.1 Duplicate determination.....	11
9.5.2 Analysis of spiked natural samples.....	11
10 Expression of results .....	11
10.1 Method of calculation.....	11
10.1.1 Entire system calibration (according to 9.3.2) .....	11
10.1.2 Argentometric measurement device calibration (according to 9.3.3).....	12
10.2 Expression of results .....	12
11 Test report .....	12
12 Performance characteristics .....	12

**Annex A** (informative) **Precision data**

**Annex B** (informative) **Storage of activated carbon**

**Annex C** (informative) **Schematic diagram of an AOX apparatus**

**Annex D** (informative) **List of matrices covered by this standard**

## Foreword

This document is a working document.

This document TC WI has been prepared by Technical Committee CEN/TC "BT/Task Force 151 'HORIZONTAL'", the secretariat of which is held by .

## Introduction

This document is developed in the project 'Horizontal'. It is the result of a desk study "Horizontal European standard for determination of AOX in sewage sludge and comparable matrices" in the project and aims at evaluation of the latest developments in assessing AOX in sludge, soil, treated biowaste and neighbouring fields. After discussion with all parties concerned in CEN and selection of a number of test methods described in this study the standard will be developed further as an modular horizontal method and validated in the project 'Horizontal' .

Until now test methods determining properties of materials were often prepared in Technical Committees (TCs) working on specific products or specific sectors. In those test methods often steps as sampling, extraction, release or other processing, analyses, etc were included. In this approach it was necessary to develop, edit and validate similar procedural steps over and over again for each other product. Consequently this resulted in a lot of duplicate work. **To avoid such duplication of work for parts of a testing procedure often was referred to parts of test methods from other TCs.** However the following problems are often encountered while using references in this way: 1) The referenced parts are often not edited in a way that they could easily be referred to, 2) the referenced parts are often not validated for the other type of material and 3) the updates of such test standards on products might lead to inadequate references.

In the growing amount of product and sector oriented test methods it was recognised that many steps in test procedures are or could be used in test procedures for many products, materials and sectors. It was supposed that, by careful determination of these steps and selection of specific questions within these steps, elements of the test procedure could be described in a way that can be used for all materials and products or for all materials and products with certain specifications.

Based on this hypothesis a horizontal modular approach is being investigated and developed in the project 'Horizontal'. 'Horizontal' means that the methods can be used for a wide range of materials and products with certain properties. 'Modular' means that a test standard developed in this approach concerns a specific step in a test procedure and not the whole test procedure (from sampling to analyses).

The use of modular horizontal standards implies the drawing of test schemes as well. Before executing a test on a certain material or product to determine certain characteristics it is necessary to draw up a protocol in which the adequate modules are selected and together form the basis for the test procedure.

**The other horizontal modules that will be available in due time are to be found in the informative annex [xxx] which contains a brief overview of the modules that are or will be worked out in the project 'Horizontal.'**

The texts of the chapters 1 to 12 are normative; annexes are normative or informative, as stated in the top lines of the annexes.

## 1 Scope

This European Standard describes an empirical method for the direct determination of organically bound chlorine, bromine and iodine (but not fluorine) adsorbed and occluded to the sample matrix. Non-volatile organically bound halogens adsorbable on activated carbon present prior to drying in the aqueous phase of the sample or adsorbed to sample surface are included in the determination.

The standard is intended for analysis of solid material, for example sludge or soil in concentrations ranging from 5 mg/kg dry matter to approximately 6 g/kg dry matter. The exact concentration range covered depends on the instrument used. Matrices for which the standard has been validated are listed in Annex D (informative).

## 2 Normative references

This European Standard incorporates by dated or undated reference, provisions from other publications. These normative references are cited at appropriate places in the text and the publications are listed hereafter. For dated references, subsequent amendments to or revisions of any of these publications apply to this European Standard only when incorporated in it by amendment or revision. For undated references the latest edition of the publication referred to applies (including amendments).

EN ISO 3696: 1997, *Water for analytical laboratory use - Specification and test methods*.

Horizontal standard module(s) on sampling of sludge, soil and waste.

Horizontal standard module(s) on pretreatment of solid materials for analysis

Horizontal standard module(s) on determination of dry residue of solid materials

## 3 Definitions

For the purpose of this European Standard, the following definition applies:

**3.1 adsorbable organically bound halogens (AOX):** The equivalent amount of chlorine, bromine, and iodine contained in organic compounds, expressed as chloride when determined according to this European Standard.

## 4 Principle

Addition of activated carbon to dried, homogenised solid sample. Elution of inorganic halides and simultaneous adsorption of water soluble organic compounds on the activated carbon by shaking with acidified nitrate solution.

Combustion of the loaded carbon / sample mixture in an oxygen stream.

Absorption of the hydrogen halides produced followed by determination of the halide ions by an argentometric titration, such as microcoulometry. Expression of the result as the mass concentration of chloride.

## 5 Interferences

Sparingly soluble or occluded inorganic halides are included in the determination and may, if present, give a significant positive bias.

Organic bromine and iodine compounds may, during combustion, decompose to elemental bromine or iodine respectively and this can yield higher oxidation states of these elements. These fractions of AOX may be incompletely determined, thus leading to negative bias.

Halogenated substances that volatilise during the drying step are lost.

## **6 Reagents**

Use only reagents of recognised analytical grade and water grade 1 in accordance with ISO 3696.

The AOX contribution from water, reagents and gases should be significantly less than the lowest AOX content to be determined. The overall AOX content of water, chemicals, and gases shall be checked by measuring the total blank (see 9.4).

### **6.1 Activated carbon**

Use an activated carbon of about 10 µm to 50 µm grain size.

For the storage of activated carbon, see annex B.

The blank value of the washed activated carbon shall be less than 15 µg of chloride equivalent per gram of activated carbon.

**6.2 Nitric acid**, HNO<sub>3</sub>,  $\rho = 1,4$  g/ml, 65% (m/m) solution.

**6.3 Hydrochloric acid**,  $c(\text{HCl}) = 0,100$  mol/l.

The molarity shall precisely be known, since the acid is used for checking the microtitration (see 9.3.3).

**6.4 Sulphuric acid**, H<sub>2</sub>SO<sub>4</sub>,  $\rho = 1,84$  g/ml.

**6.5 Gases for combustion**, for example oxygen (O<sub>2</sub>), or a mixture of oxygen and an inert gas.

**6.6 Nitrate stock solution**, acidified,  $c(\text{NaNO}_3) = 0,2$  mol/l

Dissolve 17 g of sodium nitrate (NaNO<sub>3</sub>) in water in a 1000 ml volumetric flask, add 15 ml of nitric acid (6.2), and make up to volume with water.

**6.7 Nitrate washing solution**,  $c(\text{NaNO}_3) = 0,01$  mol/l

Pipette 50 ml of the nitrate stock solution (6.6) in a 1000 ml volumetric flask, and make up to volume with water.

**6.8 Methanol**, CH<sub>3</sub>OH.

**6.9 4-Chlorophenol stock solution**, Equivalent to AOX = 2,0 g/l

Dissolve 0,725 g of 4-chlorophenol (C<sub>6</sub>H<sub>5</sub>ClO) in methanol (6.8) in a 100 ml calibrated flask and make up to volume with methanol (6.8).

**6.10 4-Chlorophenol working solutions**, Equivalent to AOX = 0,1 g/l and 0,5 g/l AOX, respectively

Pipette 5 ml and 25 ml of 4-chlorophenol, stock solution (6.9) into two separate 100 ml calibrated flasks, and make up to volume with methanol (6.8).

**6.11 2-Chlorobenzoic acid stock solution**, Equivalent to AOX = 100 mg/l

Dissolve 0,1104 g of 2-chlorobenzoic acid ( $C_7H_5ClO_2$ ) in water in a 250 ml volumetric flask and make up to volume with water.

The stock solutions (6.9 and 6.11) may be stored for at least 1 month and the working solutions (6.10) for 1 week in a refrigerator in glass bottles.

## 7 Apparatus

### 7.1 Apparatus for combustion and detection

NOTE Suitable commercial equipment is available for combustion and detection. This will comprise of the following units.

**7.1.1 Combustion apparatus**, a furnace capable of being heated to at least 950 °C, equipped with a quartz tube approximately 30 cm long with an internal diameter of between 2 cm and 4 cm (see figure C.1 in annex C).

**7.1.2 Quartz sample boat**, to fit in the quartz tube.

**7.1.3 Argentometric measuring device for determining halide concentrations**. For example a microcoulometer, capable of determining at least 1 µg chloride with a coefficient of variation (repeatability) of less than 10 %, or an equivalent device to determine chloride ions.

**7.1.4 Absorber**, filled with sulphuric acid (6.4), to dry the gas stream and designed so that the acid does not backflush into the furnace.

**7.1.5 Syringe**, to pipette volumes of 1 µl to 10 µl of hydrochloric acid (6.3) or 4-chlorophenol solutions (6.9 and 6.10).

### 7.2 Equipment for adsorption

**7.2.1 Filtration apparatus**, for example with a funnel capacity of 0,15 l and filter diameter 25 mm.

**7.2.2 Low-halide polycarbonate membrane filter**, to fit the filtration apparatus (7.2.1), with a pore size of 0,45 µm, or any equivalent filtration material, such as a dedicated quartz filter for AOX determination.

**7.2.3 Conical flask** (Erlenmeyer flask) of 25 ml capacity with ground glass stopper or 12 ml to 20 ml screw cap vial with PTFE lined cap.

**7.2.4 Mechanical shaker** for the flasks described in 7.2.3 above, equipped for example with a carrier plate.

### 7.3 Equipment for sample preparation

**7.3.1 Porcelain evaporating dish**

**7.3.2 Oven** with forced ventilation or natural ventilation through adjustable vents adjustable to  $(105 \pm 5)$  °C.

**7.3.3 Desiccator** provided with a suitable desiccant.

**7.3.4 Analytical mill** or porcelain mortar.

## 8 Sampling and sample pre-treatment

### 8.1 Sampling

Sampling should be carried out in accordance with EN yyyy:2003 (Horizontal standard module(s) for sampling of sludge, soil and waste).

Samples should be stored in suitable containers with an appropriate closure material such as PTFE. Samples to be frozen may be stored in aluminium containers pre-cleaned by heating to 450°C for minimum 4 hours or by rinsing with a non-chlorinated solvent.

Samples should be kept cold (< 8°C) and in the dark. The sample pre-treatment should take place within 24 hours of sampling. Alternatively, samples may be frozen (-18 °C) directly after sampling and kept frozen for a maximum of one month before sample pre-treatment.

### 8.2 Sample pre-treatment

Transfer a sub-sample, homogenized according to EN www:2003 (Horizontal standard module(s) for pre-treatment of solid materials) of approximately 100 g to a porcelain dish.

Dry the sample to constant weight at  $(105 \pm 5)$  °C as described in EN zzzz:2003 (Horizontal module(s) for determination of dry residue in solid materials).

Cool the dried sample in a desiccator, comminute and homogenize in an analytical mill or porcelain mortar to a particle size of no more than 0,1 mm.

Store the ground material in a desiccator or a tightly closed glass container.

NOTE The homogenised wet sample portion of approximately 100 g may alternatively be freeze-dried, which in some cases will make the homogenizing of the dried sample easier.

## 9 Procedure

The test sample taken for analysis shall have an AOX value within the optimal working range of the instrument, which is generally between 1 µg and 20 µg to 30 µg (absolute amount).

### 9.1 Adsorption and inorganic halide removal

Ensure that the dried, ground sample is homogenised by stirring or shaking before taking the sub-sample. Prepare the sample for combustion as follows:

- a) Transfer a homogenised test sample of 5 mg to 100 mg depending on the expected AOX content to a conical flask or screw-cap vial (7.2.3)
- b) Add 20 mg to 30 mg activated carbon (6.1) and 10 ml nitrate stock solution (6.6) to the sample. See note.
- c) Shake for one hour by mechanical shaker (7.2.4).
- d) Centrifuge the mixture and take off the supernatant with a Pasteur pipette taking care not to include sludge / activated carbon particles.
- e) Add 10 ml nitrate washing solution (6.7), shake for 10 min, centrifuge and take off the supernatant as described above.
- f) Repeat the washing procedure a further two times (for a total of three washings), but do not centrifuge after the last wash.



- g) Filter the suspension through a filtration system (7.2.1) using a small amount of nitrate washing solution (6.7) to ensure complete transfer of sample to the filter.
- h) Place the moist filter and the filter cake into the quartz sample boat (7.1.2) and proceed according to 9.2.

NOTE The amount of activated carbon should be the same for all test samples, blank determinations etc.

## 9.2 Combustion

The temperature in the combustion chamber (7.1.1) shall be at least 950 °C; select other operating parameters in accordance with the manufacturer's instructions.

- a) Connect the gas supply to the combustion tube and the combustion tube to the absorber (7.1.4).

Do not allow back-siphoning of the sulphuric acid into the combustion tube; this can happen if a drop in temperature or pressure occurs.

- b) Adjust the flow of gas (6.5) to approximately 150 ml/min or follow manufacturer's instructions.
- c) Introduce the quartz sample boat (7.1.2) into the heated zone of the tube, following the manufacturer's instructions.

NOTE 1 A number of experimental variables, for example the amount of activated carbon applied, the test sample size (9.1), the dimensions of the furnace, residence time, combustion temperature, and the adjustment of the gas flow (6.5) will depend on the type of apparatus and inappropriate selection may also affect the result.

NOTE 2 Some users report that carbon to sample ratios lower than 1 (1:1) may lead to incomplete combustion of the sample/carbon mixture (seen as tailing during the argentometric detection). If this is the case, the amount of activated carbon should be raised when test samples larger than 20 mg to 30 mg are analysed. The amount of activated carbon for the corresponding blank determinations should be raised as well.

## 9.3 Calibration

### 9.3.1 General

Calibrate the analytical instrument (7.1.1) daily using one of the two methods described below.

### 9.3.2 Calibration of the entire system

This is the preferred method, as the whole system is calibrated.

Calibrate the system by analysing at least three different levels of AOX covering the whole of the relevant working range (e.g. 0,5 µg; 5,0 µg and 10,0 µg Cl or 1,0 µg; 10,0 µg and 20,0 µg Cl) in the following way:

- a) Transfer 20 mg to 30 mg activated carbon (6.1) to the filtration apparatus (7.2.1) and moisten it with a small amount of nitrate washing solution (6.7).
- b) Place the moist filter and the activated carbon into the quartz sample boat (7.1.2)
- c) Inject 5 µl or 10 µl of the 4-chlorophenol stock solution (6.9) or a 4-chlorophenol working solution (6.10) giving the desired amount of AOX (see tabel 1) and proceed with combustion according to 9.2.

Table 1 — Suggested method of calibration

Volume added $\mu\text{l}$	Concentration of solution $\text{g/l}$	Amount of AOX $\mu\text{g}$
5	0,1	0,5
10	0,1	1,0
10	0,5	5,0
5	2,0	10,0
10	2,0	20,0

- d) Establish a linear relationship between amount of AOX analysed and instrument response:

$$N_i = i + s \cdot m_{Cl} \quad (1)$$

where:

$N_i$  is instrument response in Coulomb (C) or instrument dependent units;

$i$  is y -axis intercept;

$s$  is the slope;

$m_{Cl}$  is the amount of AOX analysed, in  $\mu\text{g Cl}$ .

Use the slope ( $s$ ) for subsequent calculation of mass concentrations of AOX (see 10.1.1).

### 9.3.3 Direct calibration of argentometric measuring device

In the case of microcoulometric determination, check the instrument within the relevant working range, using at least one test solution as follows:

- Inject directly with a syringe (7.1.5) a known volume within the range of 5  $\mu\text{l}$  to 8  $\mu\text{l}$  of the hydrochloric acid solution (6.3) into the titration cell.
- Measure the quantity of charge transferred in this test.

Coulometry theory assumes a 100 % current yield. But for practical purposes, it is important to determine the actual current yield. Obtain the correction factor by using equation (2):

$$Q = a \cdot Q_t \quad (2)$$

where:

$Q$  is the measured quantity of charge for the hydrochloric acid sample, in Coulomb (C);

$Q_t$  is the theoretical quantity of charge for the hydrochloric acid sample, in C;

$a$  is the correction factor.

- Obtain the theoretical quantity of charge,  $Q_t$ , using equation (3):

$$Q_t = V \cdot c_{Cl} \cdot F \quad (3)$$

where:

$V$  is the volume of the hydrochloric acid solution, in litres (l);

$c_{Cl}$  is the chloride concentration of the hydrochloric acid solution, in mol/l;

$F$  is the Faraday constant, and has a value of 96 487 C/mol.

## 9.4 Blank determination

Suspend 20 mg to 30 mg of activated carbon (6.1) in 10 ml of nitrate stock solution (6.6) and proceed in the same way as described in 9.1. See note.

Carry out at least two blank determinations in each series and use the average blank value for subsequent calculations.

NOTE The amount of activated carbon used for the blank determination should be the same as that used for test samples.

## 9.5 Quality Assurance of the overall procedure

### 9.5.1 Duplicate determination

Analyse two individual test samples of each dried, homogenised sample submitted for analysis. Establish a control limit for the difference between results for the two sub-samples based for example on precision data in Annex A or on laboratory precision data.

NOTE If the difference between repeated measurement of the same sample deviates more than the control limit from each other the sample should be re-homogenized (see 8.2) and the determination repeated.

### 9.5.2 Analysis of spiked natural samples

Analyse at least one spiked natural sample for each 10 samples in each series of samples:

Spike 50 µl or 100 µl (corresponding to 5 µg or 10 µg Cl) of the 2-chlorobenzoic acid stock solution (6.11) to an aliquot of a test sample containing 1 µg to 5 µg AOX. Establish a control limit for recovery of the spike based for example on precision data in Annex A or on laboratory precision data.

NOTE If the recovery is outside the control limits, the whole series of analyses should be repeated.

## 10 Expression of results

### 10.1 Method of calculation

#### 10.1.1 Entire system calibration (according to 9.3.2)

Calculate the mass concentration of adsorbable organically bound halogens, expressed as chloride,  $Q_{Cl}(AOX)$  using formula (4):

$$Q_{Cl}(AOX) = \frac{N - N_0}{m_T \cdot s} \text{ mg Cl/kg dry matter} \quad (4)$$

where:

## TC WI :2003 (E)

$N_0$  is the measured value for the blank, according to 9.4, in C or instrument dependent units;

$N$  is the measured value for the test sample, in C or instrument dependent units;

$s$  is the slope of the calibration curve as defined in equation (1);

$m_T$  is the mass of the dried test sample, in g.

### 10.1.2 Direct argentometric measurement device calibration (according to 9.3.3)

Calculate the mass concentration of adsorbable organically bound halogens, expressed as chloride,  $Q_{Cl}(AOX)$  using formula (5):

$$Q_{Cl}(AOX) = \frac{N - N_0}{m_T} \cdot \frac{M \cdot a}{F} \text{ mg Cl/kg dry matter} \quad (5)$$

where:

$N_0$  is the measured value for the blank, according to 9.4, in C;

$N$  is the measured value for the test sample, in C;

$M$  is the molar mass of chloride,  $M = 35,45 \cdot 10^6$  (for results expressed in mg/kg);

$m_T$  is the mass of the dried test sample, in g;

$a$  is the factor relating the theoretical to the actual quantity of charge (see equation (1));

$F$  is the Faraday constant, and has a value of 96 487 C/mol.

## 10.2 Expression of results

The result shall be expressed in mg/kg chloride (mg Cl/kg dry matter) and reported to two significant figures.

## 11 Test report

The test report shall contain the following information:

- a reference to this European Standard including its date of publication;
- precise identification of the sample;
- expression of results, according to 10.2 ;
- any deviation from this standard, and any facts which may have influenced the result. Where the test is not carried out in accordance with this standard, reference may only be made to EN xxxx:2003 in the report in case all deviations from the procedures prescribed in this standard are indicated in the report stating the reason for deviation.

## 12 Performance characteristics

Preliminary precision data obtained using DIN 38 414 Part 18: Sludge and sediment – determination of adsorbed organically bound halogens (AOX) (S18) in an interlaboratory test carried out in May 1989 are presented in table A.1 in Annex A.

**Annex A**  
(informative)

**Precision data**

**Table A.1 — Precision data of the results of AOX determination in sludge in an interlaboratory test<sup>1)</sup>**

Sample	Parameter	LAB	No.	NAP %	Mean mg/kg	s <sub>R</sub> mg/kg	CV <sub>R</sub> %	s <sub>r</sub> mg/kg	CV <sub>r</sub> %
X	Q <sub>Cl</sub> (R-AOX)	11	43	0	449,9	64,36	14,3	28,81	6,4
Y	Q <sub>Cl</sub> (AOX)	20	79	13,9	250,0	11,74	4,7	8,73	3,5
Z	Q <sub>Cl</sub> (AOX)	20	79	0	2691	250,6	9,3	101,0	3,8

X = Aqueous sewage sludge  
Y = Dry sewage sludge  
Z = Dry sewage sludge  
Q<sub>Cl</sub>(R-AOX) = AOX content after stripping and extraction  
Q<sub>Cl</sub>(AOX) = AOX content  
LAB = Number of laboratories  
No. = Number of results  
NAP = Outlier rate  
s<sub>R</sub> = Standard deviation of reproducibility  
CV<sub>R</sub> = Reproducibility coefficient of variation  
s<sub>r</sub> = Standard deviation of repeatability  
CV<sub>r</sub> = Repeatability coefficient of variation

1) The interlaboratory test was carried out using DIN 38 414 Part 18: Sludge and sediment – determination of adsorbed organically bound halogens (AOX) (S18)

Table A.1 is to be substituted by data produced using the present standard once a method evaluation interlaboratory study has been carried out.

**Annex B**  
(informative)

**Storage of activated carbon**

Activated carbon of an adequate adsorption capacity and of low content of inorganic halogenide, suitable for the AOX determination, is commercially available. After opening of the original container, the activated carbon can become contaminated with adsorbable compounds (including organic halogens), coming from the air. The activated carbon can become inactive within 5 days.

In order to keep the carbon blank low, take small quantities sufficient for one days work, for example 1,5 g to 2 g, and transfer to suitable sealed glass containers.

Use the contents of the container on the day of its opening. Discard the unused remainder at the end of the day.

Keep the remaining stock sealed. If the carbon blank is too high, use another batch after checking its blank.

**Annex C**  
(informative)

**Schematic diagram of an AOX apparatus**

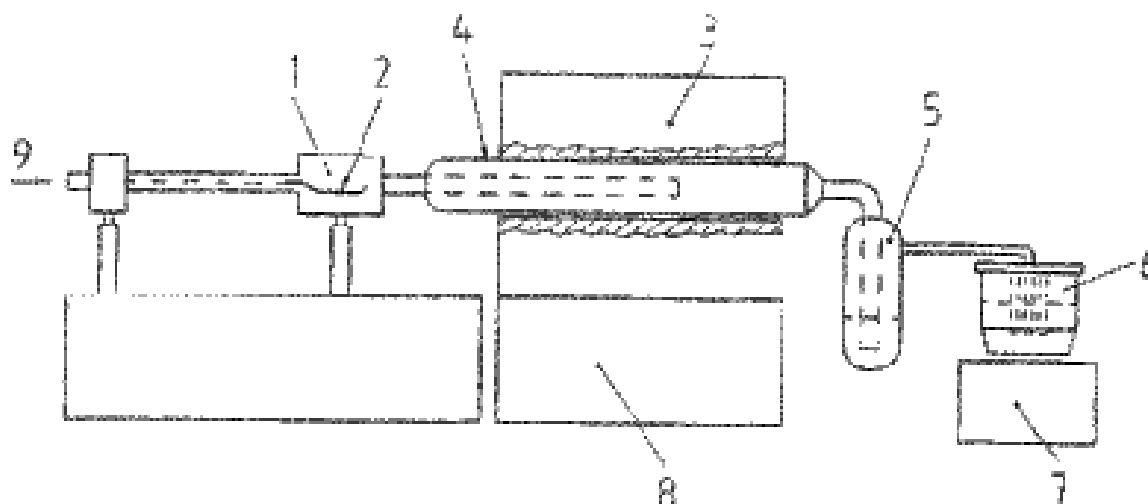

**Figure C.1 Schematic diagram of AOX apparatus**

**Key**

- 1) Sample inlet for AOX
- 2) AOX sample boat
- 3) Furnace
- 4) Combustion tube
- 5) Absorber filled with sulfuric acid
- 6) Titration cell
- 7) Stirrer
- 8) Control device for temperature, gas flow
- 9) Combustion gas inlet

Note: figure is taken from EN 1485:1996: Water quality - Determination of adsorbable organically bound halogens (AOX). Original from that standard should be used in the final version

**Annex D**  
(informative)

**List of matrices covered by this standard**

Sludge

Sediment (to be tested)

Soil (to be tested)