



Advanced System Concept & Supercapacitor for the FC - Powered Green Scooter of “FRESCO”

L. Plomp ¹⁾ and R. Hippoliti ²⁾

1) Energy research Centre of the Netherlands, PO Box 1, 1755 ZG, Petten, The Netherlands

2) Piaggio & C Spa, Viale Rinaldo Piaggio 25, 56025 Pontedera (PI), Italy



FRESCO “*European Development of a Fuel-Cell Reduced-Emission Scooter*”
is supported by the EC in the Fifth Framework Programme



PARTNERS

- ★ Energy research Centre of the Netherlands (ECN)
- ★ Piaggio & C Spa
- ★ Selin Sistemi Spa, Italy
- ★ Commissariat a l' Energie Atomique, France (CEA)



FRESCO Objectives

“To make the clean fuel-cell alternative suitable for scooters and to prove the viability by integrating a complete new power train into a mass-production type scooter”

FRESCO Technical Characteristics

- ✦ Modern, mass-production type vehicle with state-of-the-art drive characteristics
- ✦ Water-cooled PEM fuel-cell stack as prime mover
- ✦ Dedicated supercapacitor module as peak-power device
- ✦ Bi-directional traction / regenerative braking controller
- ✦ Dedicated electric rotating machine (motor / generator)
- ✦ Light-weight composite material hydrogen storage tank



FRESCO Vehicle Lay-Out

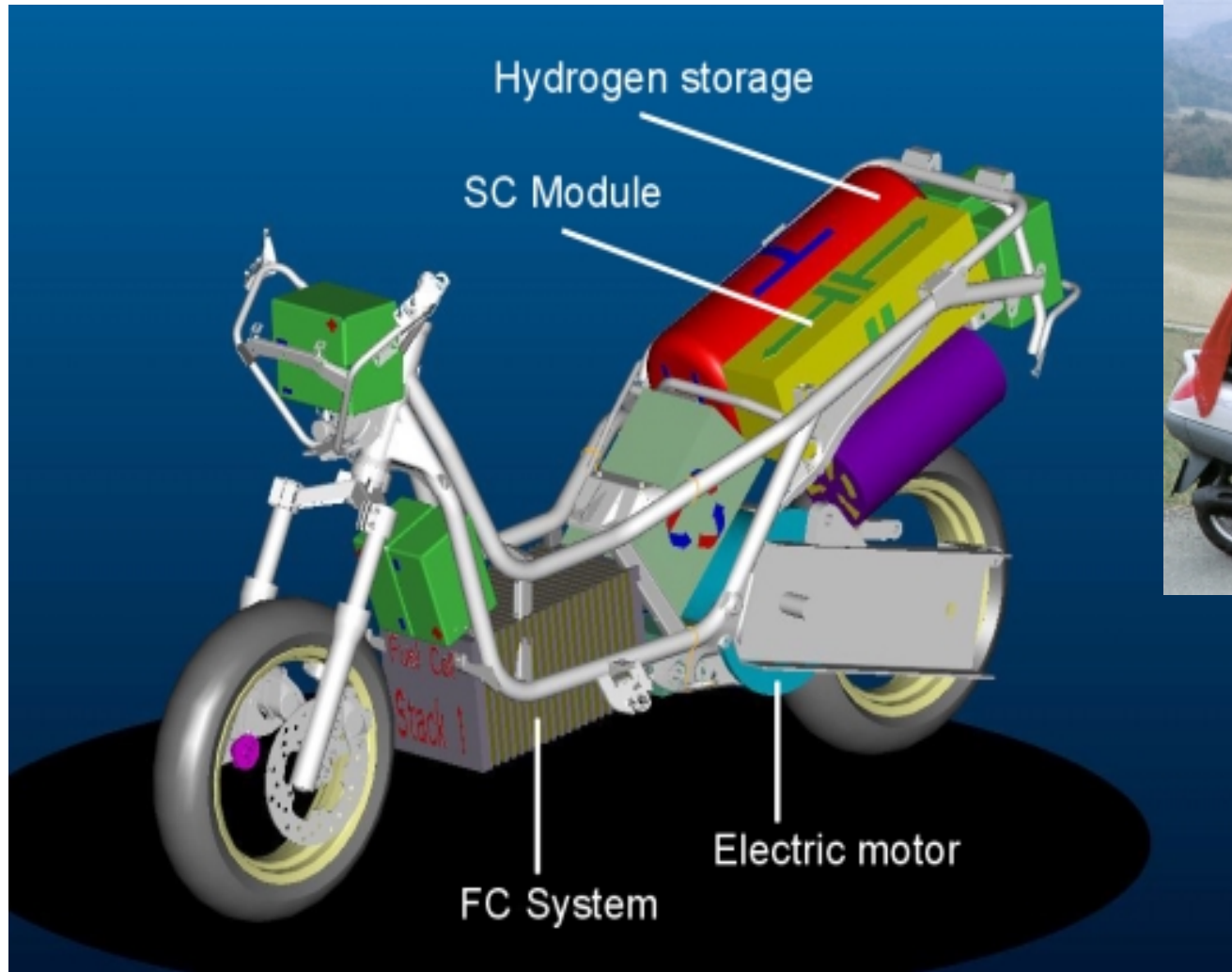

Piaggio X9



FRESCO Drive - Line System Concept

- ✦ Regenerative braking
- ✦ Minimum hardware
- ✦ Simple system control
- ✦ High dynamic stability

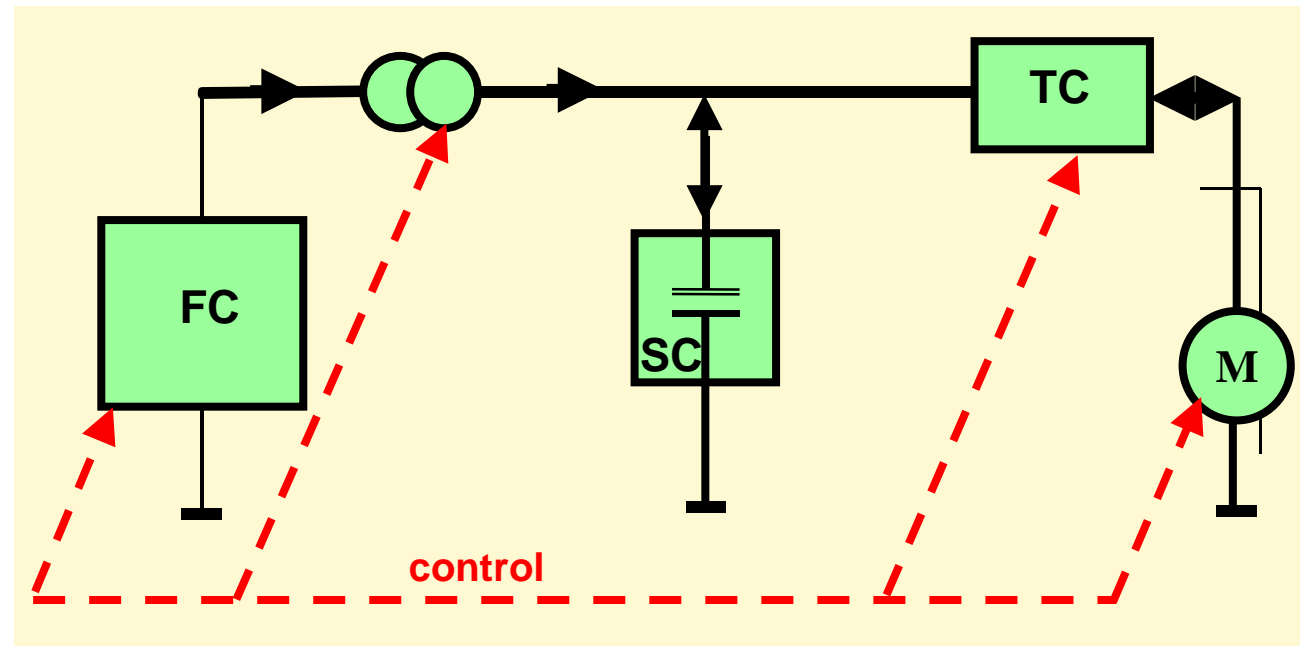

ECN Supercapacitor Development: EMX Electrode Materials

- ✦ High specific capacity
- ✦ Wide voltage window
- ✦ High electrical conductivity

	AC	RuO _x	NiOOH	EMX-1
Capacity (mAh/g)	14	98	90	95 ... 170
Conduct. (S/cm)	< 1	~300	< 10	5000
Price (Euro/kg)	2.0	3000	> 6.0	< 20

- ✦ No precious metals
- ✦ No graphite addition
- ✦ No environmental problems
- ✦ No health problems

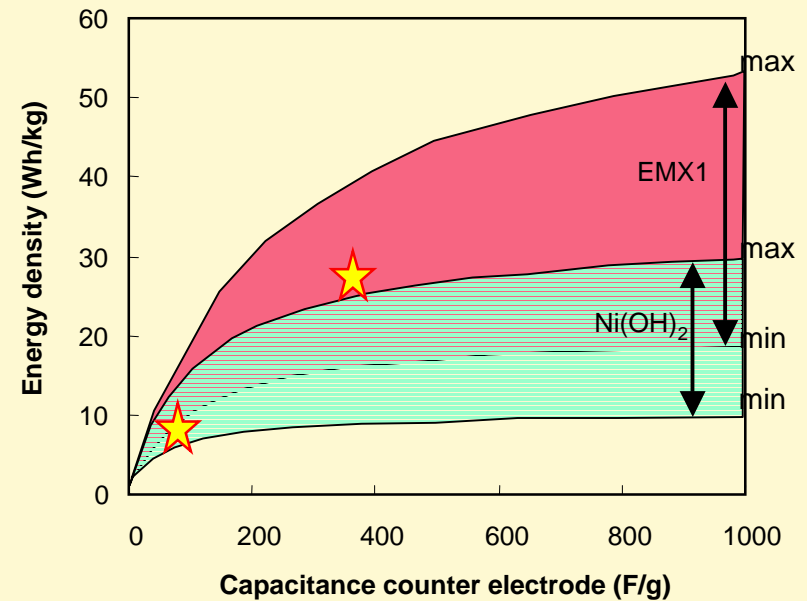

ECN PEM - FC Stack for FRESCO

Cell data at 70 °C, 1.0 bar, pure H₂

active area	275 cm ²
power	0.35 W/cm ²
cell power	96 W

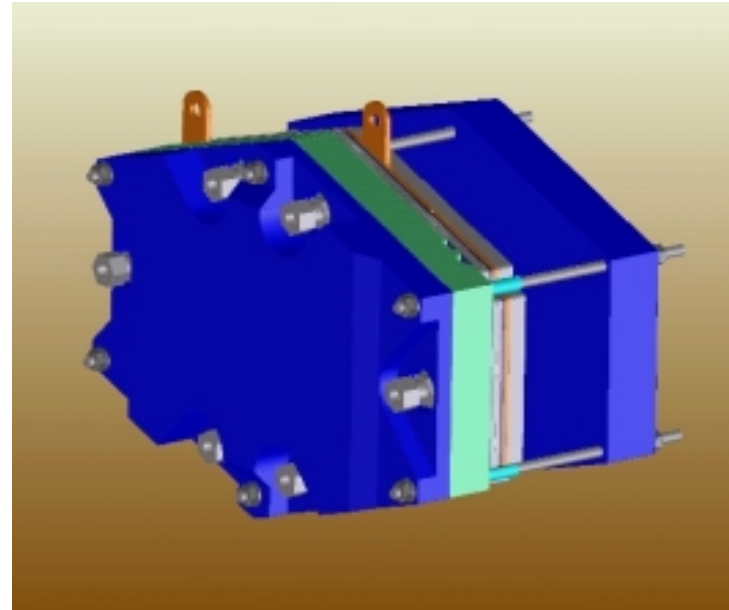

FRESCO Concluding Remarks

- ✦ Prototype scooter will be tested by the end of 2004
- ✦ FC + SC scooters will provide for clean urban transportation
- ✦ Technology suitable for various types of small vehicles

