



N·E·G MICON®

thermal resistance of soil

NM 6000

Nr: 224-JBZ-R0107_soil_resistance.doc
Rev. 0

Status: draft for comments

Cable loading due to thermal heat resistance of soil
for offshore farms

		Name:	Signature:	Date:
Written by:		JBZ Wouter Op den Velde		26/02/01
Checked by				
Signed by:				
Version	date	No of pages		
0	01/04/00	all	New	
1	24-05-02	all	Reduced information to only request of worksheet	

1.1 Index

1.1	Index.....	2
2	Introduction.....	3
3	Conclusion & comparison laying dept.....	4
4	Design drivers.....	8
4.1	To analyse failure modes.....	8
4.2	To evaluate on.....	8
4.3	Expected prizing.....	9
4.4	Conclusion.....	9
5	Worksheet / workplan.....	10
5.1	Important remarks: (each alternative of each group gets a separate description sheet).....	10
6	Discussion items.....	13
6.1	sand dunes / waves displacement.....	13
7	References.....	14

2 Introduction

From our investigation from the Dowec we have concluded that:

- The shore-cable in a windfarm are extremely important, while mostly this is a common cause failure for up to 200MW windturbines connected
- The cable cost is high, thus making an efficient use necessary
- Maximum cable loading capacity is conservative, based on ground temperature, heat conductivity and national rules & guidelines however there is a large number of uncertainties. so engineers are used to put safety margins on safety margins to be sure of the reliability making the installation inflexible and possibly expensive

•

Statement put up during the Dowec meeting

It would be wise to know more about heat resistance / conductivity of the Northsee soils the determine the loading capabilities better

Better loading of the cabling leads to reduced cost

Items and Facts collected so far

- water temp on floor level = 4°C
- knowing the heat resistance helps to determine the right burial dept
- Temperature profiling of cable circuits due to soil-type and loading
- Justify peak demands capability without reducing their life of the cable by thermal dynamic of soil
- Verification of cable calculation methods for offshore windfarms, and understanding the long term behaviour of fluctuating loading on offshore cable as with windturbines is normal
- Use of other cable installation techniques on hotspots if required

Items to fulfil as minimum

- Soil type heat resistance
- Soil type density and heat collection capacity (only needed for dynamical calculations)
- Calculate a loading factor for different soil types

Items to fulfil as option

- Prediction of heat convection by heat in soil types

Comments to that

Best is to make measurements on the cable route, estimations like in this document should never replace that
It may be wise to think about a method to determine the heat resistance at reasonable cost

During the survey, we discovered the uncertainty due to natural sand displacement. Could make this the investigation of no interest because the safety factor to calculate for worst case would take the advantages away

3 Conclusion & comparison laying dept

Thermal conductivity parameters [W/m²K] (input of v Oord)

	conductivity	Heat resistance
gravel layers typical	20 [W/m ² K] + convection	0.05 [m ² K/W]
coarse sand typical	10 [W/m ² K] + convection	0.10 [m ² K/W]
wide graded dense sand typical	2 [W/m ² K] + convection	0.50 [m ² K/W]
fine silty sand typical	1.25[W/m ² K] (no convection)	0.8 [m ² K/W]
clay typical	1.10[W/m ² K] (no convection)	0.9 [m ² K/W]

Gray is typical NorthSee

Temperature factor

temp	0	4	10	15	20	25	30	35	40	45	50	55	60	65	70	75	80
fact	1.12	1.10	1.07	1.05	1.00	0.96	0.93	0.89	0.85	0.80	0.76	0.71	0.65	0.60	0.53	0.46	0.38

←1.03
0.9 →

According information we can expect that during the windy season the cable surrounding temperature on the bottom expected on 4°C

So could be 3 % more loaded

In shallow waters <3 mtr however water temp could rise to 10.20°C

Effect on the loadability by heat conduction

North Sea

Fine sand

Clay

1	Name	Shortname	Unom	R	X	C	R0	X0	C0	Inom0	G1	Inom1	G2	Inom2	G3	Inom3
2		kV		Ohm/km	Ohm/km	uF/km	Ohm/km	Ohm/km	uF/km	A	Km/W	A	Km/W	A	Km/W	A
9	3*150/11 pir offshore	150Cu	12	0.162	0.095	0.406	0	0	0	0	0.5	495	0.8	419	0.91	400
10	3*150/20 pir offshore	150Cu	24	0.162	0.095	0.406	0	0	0	0	0.5	495	0.8	419	0.91	400
11	3*150/32 pir offshore	150Cu	36	0.162	0.095	0.250	0	0	0	0	0.5	495	0.8	419	0.91	400
12																
13																
14	3*240/20 pir offshore	240Cu	24	0.100	0.100	0.335	0	0	0	0	0.5	627	0.8	530	0.91	506
15	3*240/32 pir offshore	240Cu	36	0.100	0.107	0.250	0	0	0	0	0.5	624	0.8	528	0.91	504
16																
17	3*400/20 pir offshore	400Cu	24	0.064	0.091	0.401	0	0	0	0	0.5	775	0.8	656	0.91	626
18	3*400/32 pir offshore	400Cu	36	0.063	0.100	0.295	0	0	0	0	0.5	772	0.8	653	0.91	624
19	3*630/20 pir offshore	500Cu	24	0.039	0.124	0.295	0	0	0	0	0.5	975	0.8	825	0.91	788
20																
21	3*240/69 pir offshore->shore	240Cu	69	0.097	0.127	0.209	0	0	0	0	0.5	636	0.8	538	0.91	513
22																
23	3*240/150 pir offshore	240Cu	150	0.100	0.107	0.140	0	0	0	0	0.5	624	0.8	528	0.91	504
24	3*400/150 pir offshore	400Cu	150	0.063	0.100	0.160	0	0	0	0	0.5	759	0.8	642	0.91	613
25	3*630/150 pir offshore->shore	630Cu	150	0.039	0.124	0.193	0	0	0	0	0.5	952	0.8	805	0.91	769

Data as result of the calculation filed in vision calculation program

Effect on the loadability by heat convection

It's proven that in the seabed the convection of the water contend inside the sand can play a major rule in the heat dissipation

We can not make calculations in this, we don't have the knowledge (yet)

So we skipped the possible advantage in that matter

Possible partner to calculate it for us is Geodelft. (They do it for the cooling effect on north see heated oil pipes)

Data from poly technisch book

		Density [kg/m ³]	Heat capacitance [J/kg.K]	Conductivity [W/m.K]
1a	XLPE	924		
1b	PE	931	2200	0.3
1c	PVC	1300	1100	
2	copper	8900	390	390
3	Steel	6900	480	45
	iron	7900	460	79
4	seawater	1024	3930	convection
5	aluminum	2700	880	220
6	Sand dry	1600	800	1

$$Q = Q_{\text{conductive}} + Q_{\text{radiated}} + Q_{\text{convection}} \quad (\text{W/m}^2)$$

$$DQ = m \cdot c \cdot dT \quad (\text{heat needed for 1kg to heat } 1^\circ\text{K})$$

Static

$$Q = (T_1 - T_2) / R_c$$

$$R_c = (d_1 / \bullet_1) + (d_2 / \bullet_2) + \dots \quad [\text{M}^2\text{K/W}]$$

d_1 = Layer thickness (mtr)

\bullet_1 = Heat conduction coefficient

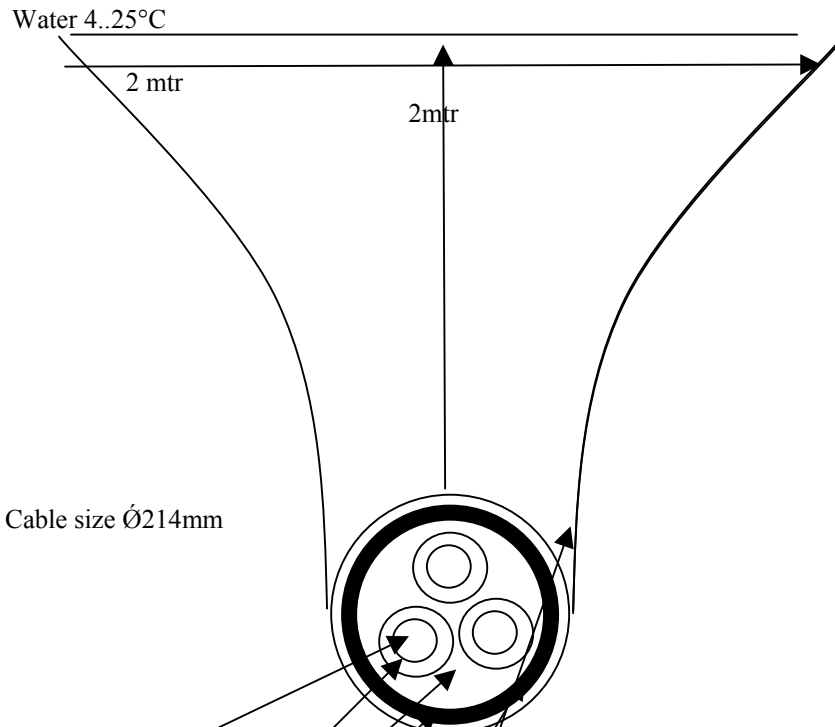

Heat development I²R per phase in copper 630mm² diameter~28.3mm A = 0.08897m² 90°C max
 150kV → 800A²* (0.024*1 / 630) = 25W each conductor = 75W /mtr total
 Copper 8900kg /mtr³ heat conductivity 390W/(m.K) heat capacity 390J/ (kg.K)

Heat transfer over XLPE layer ~22mm
 XLPE 924kg /mtr³ heat conductivity 0.3W/(m.K) heat capacity 2200 J/ (kg.K)

Heat transfer over PE filling mass ~20mm average
 PE 924kg /mtr³ heat conductivity 0.3W/(m.K) heat capacity 2200 J/ (kg.K)

Heat transfer over 5mm steel wires
 Steel 7200kg /mtr³ heat conductivity 70W/(m.K) heat capacity 480/ (kg.K)

Heat transfer over PVC layer ~10mm average
 XLPE 1300kg /mtr³ heat conductivity 0.3W/(m.K) heat capacity 1000 J/ (kg.K)

Effective area PVC to sand =Pi * D = 3.14 * 0.214 = 0.642 m²/mtr

Transfer over wide grade dense sand L =2000mm heat transfer will spread by sand /water mixture
 Sand 1600kg /mtr³ heat conductivity 1W/(m.K) heat capacity 800 J/ (kg.K) (~2m³ / mtr)
 Seawater 1024kg /mtr³ heat conductivity ?? W/(m.K) heat capacity 3930 J/ (kg.K) (~0.5m³ / mtr) (convection)

Transfer seawater by convection A =2Mtr² water will stay at environmental temp. Coastal (-10..25)/ < 4mtr = 4 °C
 Seawater 1024kg /mtr³ heat conductivity ?? W/(m.K) heat capacity 3930 J/ (kg.K)

Max Water content in: PVC < 0.4% XLPE < 1.5% PUR < 1.5% EPR(M) < 0.02%

Calculations have to be made load / cable / water temperature for static circumstances
 Temperature rise on 100 – 110% load

Temp due to heat dissipation differences

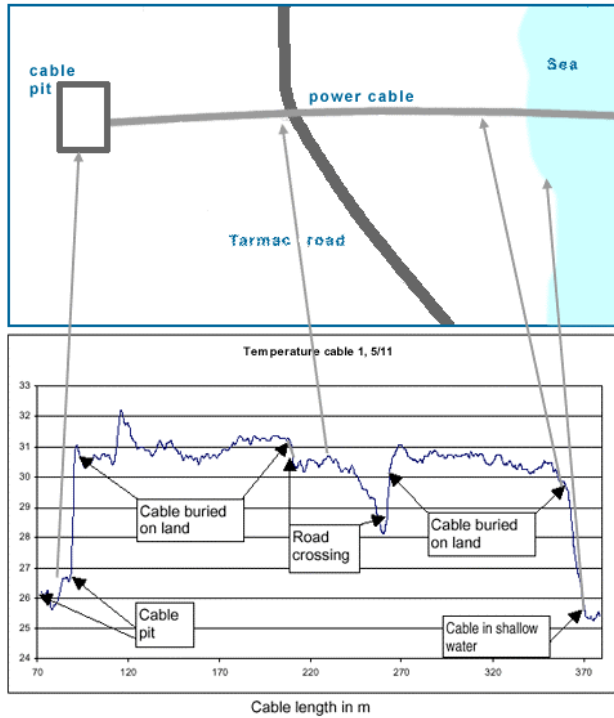

Fig. 3 Temperature profile for one power cable

Basics for heat dissipation

Heat flow comes in 2 different phenomena, conduction and convection.

Conduction:

For the pipelines the conductive resistance of the pipeline and coating (read here cable insulation, armor and coating) is combined with the conductive resistance of the soil surrounding the pipeline (cable).

One can calculate the heat-loss over a sector of the pipeline given the soil layer, dimensions, and then sum the heat loss over the full circular circumference of the cable. This defines the conductive heat loss per length unit of pipeline (cable) This method can quite simply be programmed into a spreadsheet, and quite some knowledge is available on thermal resistance values for several soil types.

Convection:

The other source of heat loss is convection of heat. The (ground) water surrounding the pipeline (cable) heats up and starts flow upward, thereby introducing fresh cold water to the surroundings of the pipeline (cable).

Thus the thermal source, i.e. the cable, introduces a groundwater flow attracting cold water from the sides, and dissipating warmer water upward.

The amount of heat-loss so generated depends not on the thermal resistance, but on the permeability of the soil in combination with the thickness of the soil layers.

When the soils are impermeable, convection does not take place.

However, sandy soils like we are considering for the North Sea routes are highly permeable. This means that conduction will be negligible compared to convection.

The experience of v Oord is that the have to take the convection in account for a sand cover, so we can conclude that if we not take this in account we will be a little pessimistic (Geo-Delft could assist to calculate better)

In what way full fill we the set-up design drivers with this design

4 Design drivers

Known soil type is knowing the heat resistance	Yes 80% certainty
20 year constant parameters	No , sand waves
	Yes
Safe control (soil changes make hotspots difficult to predict)	no
Possibilities for smart-control like dynamic loading	yes

4.1 To analyse failure modes

Effect if soil type is not constant	?
Effect of sand wave displacement	yes
Failure of cable due to overloading by overestimation	ok

4.2 To evaluate on

1	Cost / risk advantage	
2	Alternative suppliers info	Yes
3	Compliance with offshore requirements and environment	yes
4	efficiency	good
5	Weight and dimensions & possibilities to place in design	No extra weight o cable
6		
7	Reliability (proven & track record)	Ok / ?? offshore
8	Efficiency / energy yield / cost of ownership The smallest diameter is not always the most efficient diameter	ok
9	I.O.M aspects	ok
10	Grid connection aspects & power factor control range Higher loading with same capacitance is better cos.phi	excellent
11	Sales / marketing	+/-
12		
13		
14		
15		
16		

4.3 Expected prizing & Economic Benefits

Expected prizing 4 cables each 60km a 1.0 to 0.5 (J/mK)	Euro
The loadability has an indirect effect on the prizing Not further described in this paper	
10% higher loading will give mostly not a smaller number of cables	
Total	

Expected savings / year	
Loadability is an indirect saving by higher loading	
Total	-35.000/y

In a lot of installation the burial cost is at lease equal to the cable cost.

Higher loading possibilities will lead to a lower kWh prizing if the park sizing is related to the loading capacity of the cable, and possible higher flexibility is one cable has an failure

However while the factor is in the order of 10% its unlikely that less cables have to be installed

So in the loadability calculations of Dowec we used the factor of 0.8 [m°K/W]

4.4 Conclusion

It's worth to make a soil survey before final dimensioning the cabling for an offshore windfarm

To optimise the windfarm size on the cable loading, special on the shore connection

Special the dynamic response has value because my expectations is that an overload of 1.6 during 48h must be possible

The coastal area needs extra attention

Possible future development

- Optimise dimensions, weight and layout of the cable
- Develop equipment for fast & easy measurement of heat resistance to water dept of 30mtr (proposal on the appendices)
- Redesign cable to the estimate risk with lighter armour (e.g. kevlar (akzo)
- Correlate the windspeed time series & duration against the dynamic loadability of the cable

5 Worksheet / workplan

Alternative title:	9c) Thermal resistance of soil						28/03/2002	
				Group leader:	TUD, Paul Bauer			
Group:	9 Electric infrastructure			Person resp.:	TUD, Paul Bauer?			
Start date:	25-01-2002			End date:	10-05-2002			
Alt. members:	NEGM	LMGH	ECN	TUD	OORD	BALNED		
Man hours:								

Input: (number [if available], short description, time of reception, input from task [nr.])									
Objectives: (for this alternative)									
Impact of thermal resistance of soils to calculate cable loading									
Description of work: (name partner / involved people, description of work)									
NEGM	Currents Jan Bozelie								
LMGH									
ECN	Jan Pierik								
TUD	Paul Bauer								
OORD	Resistance								
BALNED									
SUBC									
Deliverables: (number, description of quantified deliverables, time of delivery)									
D	Monthly progress reports, preliminary design, report, presentation, expected pay off, interactions with other (sub)systems								
D									
Milestones and global planning including frequency of meetings:									
Seminar = start of idea Kick off meeting = set up of work plan Two-weekly contact (or more) Monthly progress meetings (February, March, April) Internal evaluation of alternative									
5.1 Important remarks: (each alternative of each group gets a separate description sheet)									

Workplan 9c

Stage 1

Contact 3 suppliers to send detailed data on these items status /by who

1a	Collect calculation methods from Pirelli /drake /documentation / v Oort	? Wouter op den Velde	
1b	Collect thermal resistance and soil data from v Oort	/done	05-02-02
1c			
	Report collected data to the group / first meeting	Wk 10	

Estimated time to finish 4 weeks

Stage 2

Calculate load / burial dept / temperature relation status /by who

2a	Input of 9c thermal resistance needed	(Paul Bauer)	
2b	Collect formula's into spreadsheet		
2c	Report trends		
2d	Take the testresults in account of the grid calculations	(Jan Bozelie)	

Estimated time to finish 2 weeks

Stage 3

3a	Write final report	(Jan Pierik / Paul Bauer)	05-02-02
3b	Review of report	All wk 14	05-02-02
3c			03-02-02

Estimated time to finish 1 weeks

Status report 25/02/2002

Stage 1

Contact 3 suppliers to send detailed data on these items

status /by who

1a	Collect calculation methods from Pirelli /drake /documentation / v Oort Calculation methods for convection not available	? Wouter op den Velde / none but known from land based installations	28-03-02
1b	Collect thermal resistance and soil data from v Oort	/done	28-03-02
1c			
	Report collected data to the group / first meeting	Wk 10 Collected data for group review	

Estimated time to finish 4 weeks

Stage 3

Draft report for comment 30/03/2002

Reviewed comments 24-05-02

6 Discussion items

6.1 sand dunes / waves displacement

Risk of cables will be covered with higher sand layers as on installation time

Influence of laying dept crossings e.g. (onshore example)

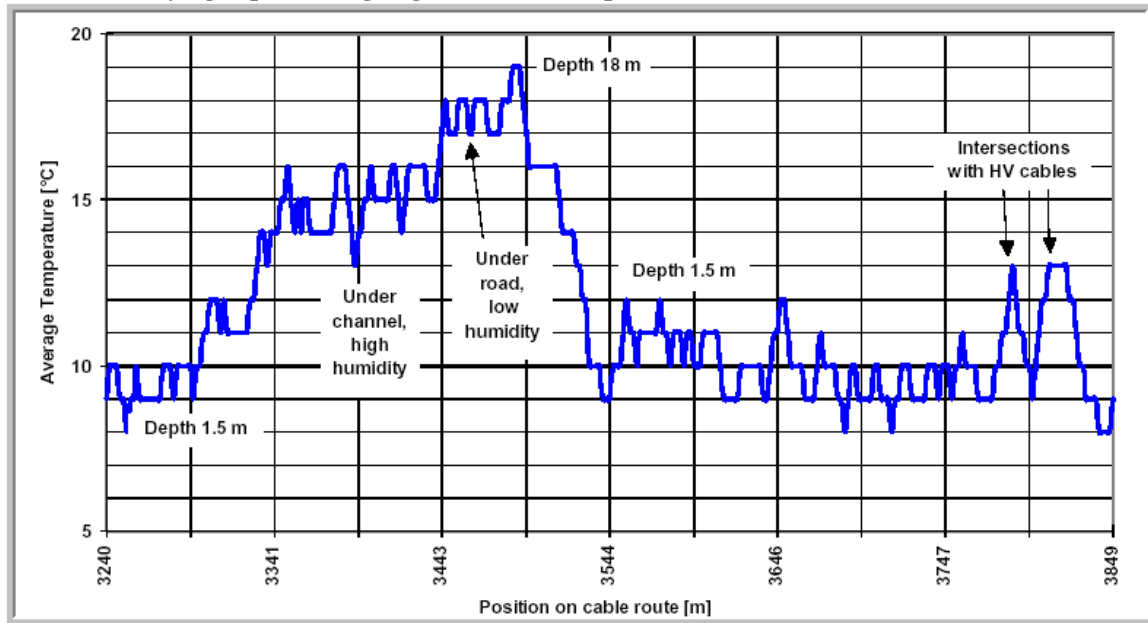

Dowec docnr 10051_000

DIEPTE VAN - TOT (m)		KORRELGROOTTE	<63um	S	GRIND	M	D50	SCHELLEN	CA
		um	%		%	um	um	%	
0.00-1.00	ZAND HOEKIG AFGEROND ZWAK SILTIG KLEUR: OLIJF BRUIN HUE 2.5Y-4/3 TAMELIJK VEEL SCHELPPFRAGMENTEN VNL. KLEPPEN VAN SPISULA ELL. TEVENS KLEP ES VAN DONAX VITTATUS	150-300		2		220		3.5	3
1.00-2.00	ZAND AFGEROND HOEKIG ZWAK SILTIG ZWAK GRINDIG KLEUR: GRIJS BRUIN HUE 2.5Y-5/2 TAMELIJK VEEL SCHELPPFRAGMENTEN VNL. KLEPPEN VAN SPISULA ELL. TEVENS KLEP ES VAN DONAX VITTATUS ENKELE FIJN GRINDJES	150-420		2.2		210		3.1	3
2.00-3.00	ZAND HOEKIG AFGEROND ZWAK SILTIG ZWAK GRINDIG KLEUR: GRIJS HUE 2.5Y-6/1 GROFSTE ZANDKORRELS STERK AFGEROND. TAMELIJK VEEL SCHELPPFRAGMENTEN (FRIS) VNL. KLEPPEN VAN SPISULA ELLIPTICA SPOOR FIJN GRIND W.O. VUURSTEEN KRISTALLIJN	150-600		2.6	1.00	310		2.5	3

Estimated laying dept 1 to 2 mtr → 0.8 [m°K/W]

7 References

- Dowec task meeting
 - Dowec docnr 10051_000 “soil types from Ballast Nedam”
 - Typical heat resistance from v Oort
 - Offers and returned datasheets added to this document
 - Pirelli cable / NKF / DRAKA cable brochures
- Most files can be found in Dowec / dir “107_grid”

Cable example Cu 630mm²

PIRELLI CABLES AND SYSTEMS



Typical cross section for 3-core XLPE insulated cable

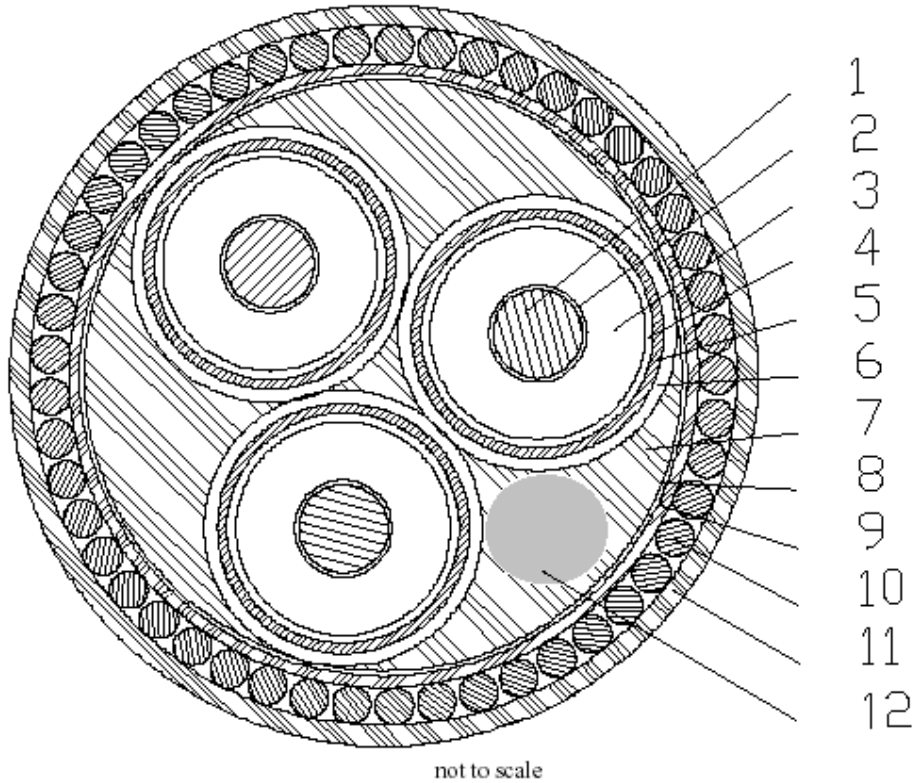

not to scale

1	Conductor: copper compact strand
2	Conductor screen: extruded semiconducting compound
3	Insulation: XLPE
4	Insulation screen: extruded semiconducting compound + Water blocking layer
5	Metallic sheath: lead alloy "E"
6	Core sheath: PE compound
7	Filler: polypropylene
8	Binder: synthetic tape
9	Bedding: polypropylene
10	Armour: galvanised steel wires
11	Serving: polypropylene
12	Optical fibre cable